



European  
Commission

JRC SCIENTIFIC AND POLICY REPORTS

# 2012 JRC wind status report

Technology, market and  
economic aspects of wind  
energy in Europe

Roberto Lacal Arántegui, main author.

Teodora Corsatea and Kiti Suomalainen,  
contributing authors.

2012

Report EUR 25647 EN



Joint  
Research  
Centre

Cover picture: Sunset at a wind farm. © Jos Beurskens.

European Commission  
Joint Research Centre  
Institute for Energy and Transport

Contact information

Roberto Lacal Arántegui

Address: Joint Research Centre, Institute for Energy and Transport. Westerduinweg 3, NL-1755 LE Petten, The Netherlands

E-mail: [roberto.lacal-arantegui@ec.europa.eu](mailto:roberto.lacal-arantegui@ec.europa.eu)

Tel.: +31 224 56 53 90

Fax: +31 224 56 56 16

<http://iet.jrc.ec.europa.eu>

<http://www.jrc.ec.europa.eu>

This publication is a Reference Report by the Joint Research Centre of the European Commission.

Legal Notice

Neither the European Commission nor any person acting on behalf of the Commission is responsible for the use which might be made of this publication.

Europe Direct is a service to help you find answers to your questions about the European Union

Freephone number (\*): 00 800 6 7 8 9 10 11

(\*) Certain mobile telephone operators do not allow access to 00 800 numbers or these calls may be billed.

A great deal of additional information on the European Union is available on the Internet. It can be accessed through the Europa server <http://europa.eu/>

JRC77895

EUR 25647 EN

ISBN 978-92-79-27955-3 (pdf)

ISBN 978-92-79-27956-0 (print)

ISSN 1831-9424 (online)

ISSN 1018-5593 (print)

doi:10.2790/72493

Luxembourg: Publications Office of the European Union, 2013

© European Union, 2013

Reproduction is authorised provided the source is acknowledged.

Printed in the Netherlands

## Table of content

Abbreviations and acronyms: .....	6
Executive summary .....	7
1. Introduction .....	8
2. Technology status.....	9
2.1. Current wind energy state-of-the-art.....	9
2.1.1. Wind turbine design.....	9
2.1.2. Drive train designs – exciting new concepts.....	11
2.1.3. Materials .....	12
2.2. Technological developments .....	14
2.2.1. Blades .....	16
2.2.2. Gearboxes .....	17
2.2.3. Electricity generators .....	18
2.2.4. Power converters .....	20
2.2.5. Towers .....	20
2.2.6. Offshore wind: farther and deeper.....	21
2.2.7. Offshore support structures.....	22
2.3. Current challenges and possible bottlenecks .....	24
2.3.1. Technology challenges .....	24
2.3.2. Project management challenges .....	24
2.3.3. Challenges of the context.....	25
2.4. Future technological evolution.....	27
2.4.1. Technology.....	27
2.4.2. Project management .....	28
2.4.3. The context.....	29
2.5. Role of European industry on global technology and innovation.....	29
2.5.1. European actors and institutions.....	29
2.5.2. International competition.....	31
2.5.3. Interactions between actors and environmental policies.....	31
3. Wind energy market status.....	33
3.1. Global market status.....	34
3.1.1. The European Union and beyond in Europe.....	34
3.1.2. China.....	35
3.1.3. North America .....	35
3.1.4. Rest of the world.....	35
3.2. Analysis and projections.....	36
3.3. Turbine manufacturer’s market.....	37
3.4. Repowering old wind farms.....	39
3.5. Industrial strategies .....	39
3.6. Deployment scenarios .....	42

4.	Economic impacts of wind energy .....	45
4.1.	Economic indicators .....	45
4.2.	Economic aspects .....	46
4.2.1.	Turbine costs .....	46
4.2.2.	Capital expenditure (CapEx) .....	48
4.2.3.	Operational expenditure (OpEx) - general .....	50
4.2.4.	Operational expenditure (OpEx) - offshore .....	50
4.2.5.	Technology learning .....	52
4.2.6.	Integration in the electricity system.....	53
4.2.7.	Energy produced.....	53
4.2.8.	Cost of energy.....	54
4.2.9.	Approaches to reducing the cost of energy .....	56
4.2.10.	Conclusion on costs.....	57
4.3.	Other economic impacts.....	58
4.3.1.	Wind and electricity prices.....	58
4.3.2.	Feed-in-tariffs .....	59
4.3.3.	Employment impacts.....	60
5.	References: .....	62

## Acknowledgements

The authors would like to thank the internal and external experts who reviewed the draft report and contributed with great ideas to the improvement of this report. There are: Ms Karin Ohlenforst, Vestas Wind Systems A/S; Ms Athanasia Arapogianni, European Wind Energy Association; Dr Henning Kruse Siemens Wind Power A/S; Ms Katja Birr-Pedersen, Dong Energy; and very specially to Dr Birte Holst Jørgensen, Risø Laboratory, Technical University of Denmark. At the different services of the European Commission: Dr Ir. Matthijs Soede, DG Research & Innovation; Mr. Balázs Józsa, DG Energy; and Dr Lin Luo, Dr. Raymond Moss and Dr Stathis Peteves, JRC.

Some of the ideas suggested by the reviewers that will be included in the next issue of this report include: a brief description of the most recent and relevant EU-supported R&D projects; an analysis of the innovation systems in the offshore subsector; a sketch of R&D investment under the EU SET-Plan; a description of the industrialisation of wind turbine manufacture; projections of offshore development based on the expected project commissioning year and coupled to the expected reduction in the cost of energy; a description of novel ideas in wind drive trains such as the hydraulic drive train; additional data on wind curtailment in Member States; a more detailed presentation of European feed-in tariffs; deeper analysis of the competition in the sector, e.g. through the Hirfindahl-Hirschmann index (HHI)<sup>1</sup>; and projections of rare earth demand along with projections of expected supply.

---

<sup>1</sup> A commonly accepted measure of market concentration. See <http://www.investopedia.com/terms/h/hhi.asp>

**ABBREVIATIONS AND ACRONYMS:**

Throughout this report 2-letter country codes are used as for the International Organization for Standardization: [http://www.iso.org/iso/country\\_names\\_and\\_code\\_elements](http://www.iso.org/iso/country_names_and_code_elements). Other abbreviations and acronyms are:

bn	Billion (1 000 million)
CapEx	Capital expenditure, or capital cost
CF	Cohesion Fund
CoE	Cost of energy
DD	Direct-drive
DFIG	Doubly-fed induction electricity generator, also called DFAG (A for asynchronous)
EEA	European Economic Area, includes the EU plus Iceland, Liechtenstein and Norway.
EMG	Electromagnet generator
FP	Framework Programme for Research and Technological Innovation
EIB	European Investment Bank
EPO	European Patent Office
EBRD	European Bank for Reconstruction and Development
ERDF	European Regional Development Fund
EU	European Union
GW	Gigawatts (= 1 000 000 000 Watts)
HTS	High-temperature superconductor
IEE	Intelligent Energy Europe programme of the European Commission
IGBT	Insulated-gate bipolar transistor
JRC	Joint Research Centre, a directorate general of the European Commission
JTI	Joint Technology Initiative
kW	Kilowatts (= 1 000 Watts)
LCoE	Levelised cost of energy
m	Million
MW	Megawatts (= 1 000 000 Watts)
OEM	Original equipment manufacturer, in the context of this report OEM is the wind turbine manufacturer.
OpEx	Operational expenditure or O&M cost
O&M	Operations and maintenance
PM	Permanent magnet (s)
PMG	Permanent magnet generator (s)
RD&D	Research, development and demonstration
RPM	Revolutions per minute
R&D	Research and development
SCIG	Squirrel-cage induction (or asynchronous) electricity generator
SET-Plan	(European) Strategic Energy Technology Plan [EC, 2007]
WIPO	World Intellectual Patent Organization
WRIG	Wound-rotor induction (or asynchronous) electricity generator

## EXECUTIVE SUMMARY

The wind energy sector uses a mature yet continuously improving technology. The reliability of wind turbines and the efficiency of energy capture are both high, yet continue to improve with new designs, new components and new materials. Even non-technological aspects such as project management, better forecasts of wind energy production and better risks assessment are contributing to increasing the competitiveness of wind power and reducing its overall cost. This is sometimes achieved even if some cost areas can occasionally increase, e.g. capital costs due to the better quality of components.

To further increase reliability, scientists and designers require better knowledge of loads, load effects and electrical effects in the mechanical and electrical parts of the turbine. They also require materials and basic components (e.g. electronic components of the electricity subsystems) that can stand higher temperatures and perform better at normal operating temperatures. In some areas reliability is improved through more redundancy of equipment, in particular in control and power electronics.

The technological aspects of wind energy include:

- Wind turbine components: blades, forgings (e.g. main shafts), castings (e.g. hubs, bearing housings and bed plates), pitch, control and yaw systems, generator, gearbox, bearings and shafts, and power electronics.
- Design for manufacture, transport and installation; turbine assembly.
- Offshore foundations design and manufacture; and foundations, cable and turbine installation.
- Substations: switchgear, transformers, cables, circuit breakers, etc.

The world wind market and the European offshore sectors are continuously growing although European onshore wind growth is less significant. Overall, the global annual market remains stable at around 40 GW of installed capacity, but this figure hides huge variations between individual markets. Cumulative installed capacity reached 240 GW at the end of 2011 and is expected to reach 285 GW at the end of the current year (2012).

The 2011 manufacturers market continued to be dominated by Vestas and, as in 2010, it included four Chinese firms among the top-ten. However, the changes in the Chinese market are very significant as the 2010 market leader Sinovel (and 2<sup>nd</sup> worldwide) is now 7<sup>th</sup> worldwide. European firms, General Electric (US) and Suzlon (India) have a truly international reach whereas Chinese firms are still confined to the Chinese market.

Capital expenditure (CapEx) or cost for wind installations vary greatly worldwide: unit costs in some countries can be triple those in other countries. Overall, 2011 CapEx for onshore wind averaged 1 580 €/kW, if Chinese and Indian installations are excluded (due to different cost methodologies), and the offshore figure reached 3 500 €/kW although from a low installed capacity basis. Operational costs (OpEx) are also very different onshore (21 €/MWh) and offshore (32 €/MWh, figures depend on assumptions such as capacity factors). There is a clear trend to lower prices in both CapEx and OpEx, possibly steeper in onshore than offshore OpEx and with very significant potential in offshore CapEx.

This report presents a snapshot of the current situation of the wind sector from a technology and market perspective, and a detailed analysis of the economics of wind. It is the first of a series of annual reports which will not only include annual developments but also specific, one-off research into technology aspects of the wind sector.

## 1. INTRODUCTION



Figure 1: wind turbines at dawn. © Jos Beurskens.

This is the first edition of an annual report with which the Energy Systems Evaluation Unit of the Institute for Energy and Transport<sup>2</sup> wants to contribute to the general knowledge about the wind energy sector, its technology and economics with a focus on the European Union.

Wind power is the renewable energy which has seen the widest and most successful deployment over the last two decades, from 3 GW to above 280 GW of global cumulative capacity expected at the end

of 2012. In Europe, the 100-GW mark was surpassed by September 2012, and already in 2011 four countries (DK, PT, IE, ES) obtained more than 10 % of their electricity from wind. Wind energy will provide at least 12 % of European electricity by 2020. This is a very significant contribution to the 20/20/20 goals of the European energy and climate policy.

This report is centred on the technology, market and other economic aspects of wind energy in Europe and, because the wind sector is a global industry, some sections have a global scope. The report is based on the core JRC research work in wind technology; on work done for the European Wind Industrial Initiative; on our own databases of wind turbines and installations and on models and other internal research; on research by key actors from industry and academia; and on direct industry consultation.

The report is made of regular sections which will constitute the core of subsequent annual reports, and of ad-hoc research chapters focusing on specific technology issues. Section 2 investigates the technological situation: state-of-the-art of wind turbines and of their main components, research, innovations, current challenges and possible bottlenecks, and its possible future evolution. Section 3 focuses on the wind market status, both globally and in Europe; proposes some deployment scenarios and analyses industrial strategies as made public by manufacturers and developers. Section 4 analyses the economic aspects and implications: cost aspects focus on turbine costs, capital costs (CapEx), the cost of operating the facility (OpEx), and the resulting cost of the energy produced (CoE). Other socio-economic aspects touched upon include the amount of energy produced, the value of wind to the society and employment.

Ad-hoc research in this issue of the JRC wind report includes the rise of permanent magnet electricity generators in wind turbines and an analysis of wind patents.

---

<sup>2</sup> One of the seven institutes of the Joint Research Centre of the European Commission, see <http://ec.europa.eu/dgs/jrc/index.cfm>



## 2. TECHNOLOGY STATUS

The kinetic energy of the wind is transformed into mechanical energy by the rotors of wind turbines and then into electricity by generators that inject the electricity into the grid. Wind speed is the most important factor affecting turbine performance because the power that can be extracted from the wind is proportional to the cube of the wind speed, e.g. an increase in the long-term mean wind speed from, for example, 6 to 10 m/s (67 %), causes a 134 % increase in production [EWEA, 2009a]. Wind speed varies depending on the season, location, orography and surface obstacles and generally increases with height, creating the wind shear profile. Surface obstacles, such as forests and buildings, decrease the wind speed, which accelerates on the windward side of hills and slows down in valleys. Annual variations up to 20 % are normal.

A wind turbine starts to capture energy at cut-in speeds of around 3 m/s (11 km/h) and the energy extracted increases roughly proportionately to reach the turbine rated power at about 12 m/s (43 km/h), remaining constant until strong winds put at risk its mechanical stability, thereby forcing the turbine to stop at the cut-out speeds of around 25 m/s (90 km/h). Once stopped and secured turbines are designed to withstand high wind speeds up to 60 m/s (216 km/h) [JRC, 2011a]. Generally, utility-scale wind farms require minimum average wind speeds of 5.5 m/s.

There are two main market sectors: onshore and offshore. The differences include more complex installation offshore, working environment (saline and tougher at sea) and facility of access for installation and maintenance. In addition, as the wind is stronger and less turbulent at sea, wind turbine electricity production is higher offshore.

Current onshore wind energy technology is mature although it certainly has room for further improvement, e.g. locating in forests and facing extreme weather conditions. Offshore wind, however, still faces many challenges. There is a third sector, small turbines (up to 10 kW) for niche applications such as isolated dwellings, but this sector is unlikely to provide a significant share of the European electricity supply by 2020 and therefore is not treated here.

At the end of the last century, a wind turbine design (the three-bladed, horizontal-axis rotor) arose as the most cost-effective and efficient. The main technological characteristics of this design are: an upwind rotor with high blade and rotor efficiency, low acoustic noise, optimal tip speed; active wind-speed pitch regulation; variable rotor speed with either a gearbox connected to a medium- or high-speed generator or direct rotor connection to a low-speed generator; and concrete, steel or hybrid towers.

### 2.1. Current wind energy state-of-the-art

#### 2.1.1. Wind turbine design

Out of a wide variety of wind turbines, in the 1980s the Danish three bladed, single fixed speed, stall-regulated turbine became the dominant model in the market at rated power levels of less than 200 kW. Since then turbine dimensions have grown steadily and by 2006, 2 MW turbines were commonly installed in onshore projects. Recently, 2 MW or above is the average size of turbines installed in 2011 in most western countries [BTM, 2012].

The main technological characteristics of current turbines are:

- Steel, concrete or hybrid towers reaching 140m of height.
- An upwind rotor with three blades, active yaw system, preserving alignment with the wind direction. Rotor efficiency, acoustic noise, tip speed, costs and visual impact are important design factors. Some turbine designs have only two blades.

- High-wind-speed regulation. Pitch regulation, an active control where the blades are turned along their axis to regulate the extracted power.
- Variable rotor speed. It was introduced to allow the rotor and wind speed to be matched more efficiently in particular at lower wind speeds, and to facilitate an output more according with the needs of the electricity grid.
- A drive train system where a gearbox adapts the slow-rotating rotor to the needs of a fast electricity generator. However, more and more slow generators are used directly coupled to the turbine rotor.

Although simpler designs are cheaper - in terms of up-front investment- and at times more reliable, this technology has proven to increase efficiency of energy extraction, to allow higher power outputs and –a crucial issue- to provide electricity better adapted to the quality demanded by grid operations.

The main wind turbine design driving goals are to minimise capital costs and to maximise reliability, which translate into: specific design for low and high wind sites, grid compatibility; acoustic performance, aerodynamic performance, visual impact and offshore specifics. Technical considerations that cover several of these goals include low-mass nacelle arrangements, large rotor technology and advanced composite engineering and design for offshore foundations, erection and maintenance.

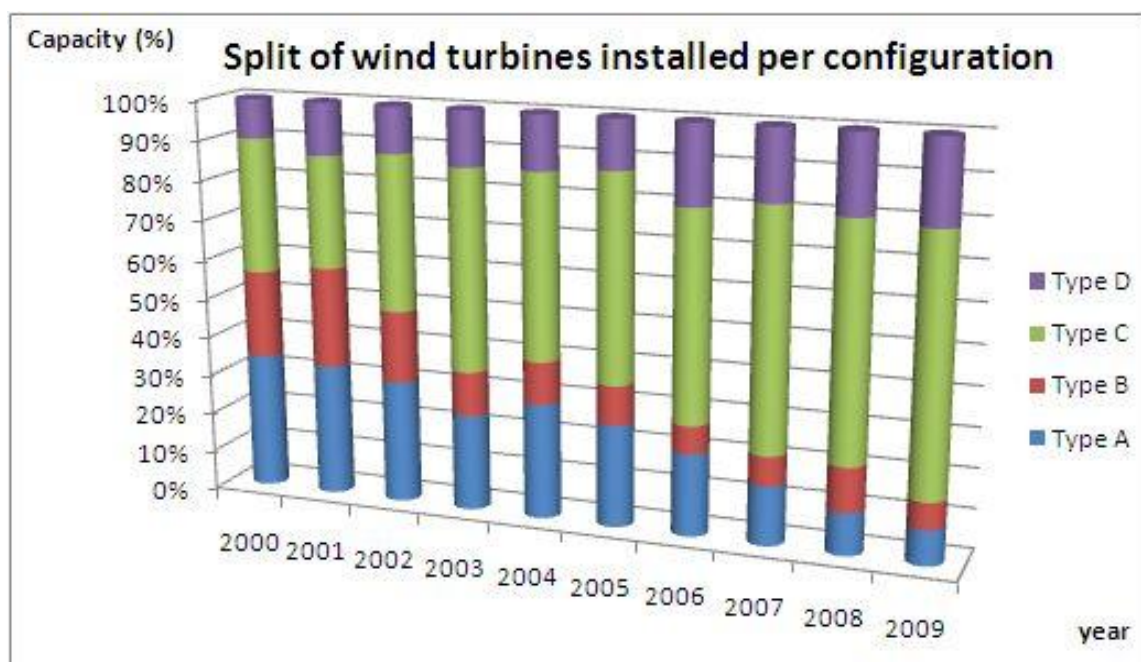

Figure 2: Evolution of the share of installed capacity by turbine configuration. See box 1 for a definition of the different types. Source: Llorente et al. [2011]

Increasingly demanding grid codes are having an impact on turbine design. The type C turbine configuration (see box 1) is currently the most popular design, but type D offers more flexibility thanks to a full power converter (FC)<sup>3</sup>. In particular along with a permanent magnet generator (PMG), a type D configuration allows easier compliance with the most demanding grid “fault ride-through” capabilities required by recent grid codes. The transition from type C to type D is accelerating as power electronics become increasingly more affordable and reduce the importance of one of the key cost arguments for type C, the high cost of power electronics. Figure 2 shows

<sup>3</sup> For a full explanation of why and how a FC offers flexibility see e.g. Llorente et al. [2011]

the trend in these different technologies, given in the classification of types A, B, C and D, as defined in box 1.

Technology developments are also occurring in the growing offshore wind industry, where the design of foundations and cable connection is as important as that of turbines. The most popular foundations are monopiles and, to a lesser extent, gravity-based foundations for shallow-to-medium water depths. Table 6 (in section 2.2.7) shows the split of installed foundations per type. Jacket foundations are more expensive than monopiles but they are becoming more common because they are cost-effective for multi MW turbines above 4 MW and at depths of 40 – 60 m. Much less common and, in fact, mainly experimental, are tripod, tripile and floating foundations. The latter are being explored in order to capture the very large resource available in deep-water areas; the first deep-water wind farm is envisaged for 2020 in Japan.

The two key issues for offshore wind design are increasing turbine reliability and reducing costs. Increasing reliability will have an impact on a number of current challenges in offshore wind farms, e.g. reducing maintenance stops, which translates to reducing the need to access the wind farms in rough sea conditions. Reduction of costs is partly met by increasing reliability, but also by improving the design of the whole system, e.g. the coupling between the foundation and the installation vessels in order to reduce installation time; more cost-effective foundations and installation for sites in deeper waters and farther offshore; and by reducing the cost of interconnection, currently at about 20–25 % of capital expense.

Box 1: wind turbine configurations

**Type A** Fixed-speed, no power converter - the “Danish model”.

**Type B** Slightly variable speed, no power converter – the “advanced Danish model”.

**Type C** Variable speed, doubly-fed induction generators (DFIG) with a partially-rated power converter

**Type D** Variable speed, direct drive, and full-scale power converter with either electromagnet or permanent magnet electricity generators.

A sketch of types C and D is included in section 2.2

### 2.1.2. Drive train designs – exciting new concepts

Drive train design is currently one of the most active areas of innovation [Jamieson, 2011]. New designs are appearing in the megawatt range using permanent magnet generators (PMGs), some of them direct drive (DD) and others with one, two or three stages of gearing.

The main objectives in drive train innovation are related to:

- Improving reliability: an example is the DD concept which eliminates the gearbox
- Improving efficiency: part load efficiency is especially relevant
- Reducing costs: either by searching for the most cost effective system or by radical concept changes, e.g. by more integrated design

New designs aim at solving the weaknesses of the gearbox – DFIG configuration (type C) in terms of power quality, offering as well a wider speed range. Superconducting generators promise large mass reductions for high-capacity turbines, but there are still many technical challenges to be solved. The need to maintain cryogenic systems and in particular the time to cool down the system and restore operation after a maintenance or other stoppage are some of the concerns.

Direct drive systems are increasingly popular new designs. The long-term established solution on the market is an excited synchronous generator with wound field rotor design offered mainly by Enercon. At the same time with the historical availability of comparatively inexpensive high strength neodymium magnets, in recent years the direction of development was predominantly towards PMG designs. However, the 2011 abrupt peak in the price of rare earth elements, including neodymium, and the perceived risk of scarcity and price/material manipulation, certainly influenced the cost of DD-PMGs. One of the consequences is a revitalisation of the

hybrid PMG concept, which involves a medium-speed generator, because a generator running at high speed is much smaller than one running at low speed and therefore uses less rare earths (see Table 1).

Item	Type C	Type D	Hybrid
Gearbox	3-4 stages, high speed	None	1-2 stages, medium speed
Generator	DFIG (1200 – 1800 RPM)	Electromagnet or PM, low speed (8–20 RPM)	Medium-speed PM (60 – 600 RPM)
Rare earth use	None	(if PM) 160-200 kg/MW	40 - 60 kg/MW
Power converter	Partial	Full	Full

Table 1: Comparison of the key drive train elements for type C, type D and hybrid drive trains. Rare earth use is approximate for a 3-MW turbine. See JRC [2012c] for an analysis on rare earths use in PMG.

Regarding generator speed, turbine designs under types A, B and C always use high-speed electricity generators, and type D sometimes; medium- and low-speed generators only fit in a type D design. Because the lower the speed of an electricity generators the larger its size, a medium speed generator has a larger diameter than a high-speed one - but induction (asynchronous) machines are generally less attractive at low speeds and large diameters [Jamieson, 2011]<sup>4</sup>. Therefore only synchronous machines, especially PMGs, are considered at medium and low speeds, although some other designs, such as the switched reluctance generator, have been explored.

The options for electrical power conversion depend on the turbine configuration (see box 1 and Figure 3 in section 2.2). By default types A and B do not include power conversion, although a hybrid configuration including, e.g. a simple squirrel-cage induction generator could use full conversion to optimise output quality<sup>5</sup>. Type C can only use a partial converter whereas type D can only use a full converter.

Main trends in wind drive-train technologies include:

- Speed variation. Various solutions exist from high slip in a single generator to a variety of variable speed systems.
- Direct drive systems and permanent magnet generators are becoming increasingly more common, often both options together.

For example, on the use of permanent magnets in wind turbines, Oakdene Hollin's [2010] study on rare earth elements estimated that 20% of global wind turbine installations between 2015 and 2020 were likely to use permanent magnets, rising to 25% by 2030. For Europe these values are estimated to be 15% by 2020 and 20% by 2030 [JRC, 2011b]. In section 3.6 below, the JRC presents its latest scenarios and the reasoning behind them.

### 2.1.3. Materials

The main components of wind turbines are blades, hub, main shaft, gearbox, generator and power converter, all hosted in a nacelle supported by a bedplate, mounted on a tower. Direct

<sup>4</sup> For example, a 6-MW PMG can have a diameter of 8 m whereas a medium speed PMG of slightly lower rating (3.3 MW) can have a 2.6 m diameter.

<sup>5</sup> Siemens' flagship configuration for the last six years is the NetConverter® concept which combines a high-speed, "simple" squirrel-cage induction generator, which generates at variable frequency and voltage, with a full converter that transforms the electricity to cover the most-demanding grid codes. Machines with this configuration included SWT-2.3-82 VS, SWT-2.3-93, SWT-2.3-101, SWT-2.3-108, SWT-3.6-107, and SWT-3.6-120.

drive turbines have no gearbox and are equipped with a low-speed generator. A JRC study [2012c] investigated the material use and future needs of these components.

Table 2 summarises the main materials used in turbines with two different configurations, type C (DFIG) and type D (DD).

Model characteristics	V80-2 MW, DFIG, 78-m steel tower	90-m rotor, 2MW DFIG 105-m hub, steel tower	E82 E2, 2.3MW DD-EMG, 107-m pre-cast concrete tower	70-m rotor, 1.8 MW DD-EMG, 65-m hub steel tower
Steel	236	296	246	178
Concrete	805	1 164	1 880	360
Iron or cast iron	20	40	73	44
Resins	3	10	-	4.8
Fibre glass	21.5	24.3	29	10.2
Copper	3	2.4	11	9.9
Aluminium	1.7	-	1.3	
Source	Elsam [2004]	Guezuraga et al [2011]	Zimmermann [2011]	Guezuraga et al [2011]

Table 2: Materials composition of two wind turbines, in tonnes.

Blades are made of fibre-reinforced polymers (resins) in the form of laminates or sandwich substructure. Traditionally blades were made around glass fibre and polyester resin. Current materials include as well epoxy resins reinforced mainly with glass fibres, and to some extent with the lighter but more expensive carbon fibres. Structural parts, e.g. the sandwich parts, are mostly made from polymer foam or balsa wood although some manufacturers may complement these with steel. Fibre surface treatments including coatings used to protect against sand and water droplet erosion, aging from UV radiation, and to improve ice shedding efficiency in cold conditions. The blades are mostly produced in two halves, the upper and lower part, and are joined using adhesive bonding.

The rotor hub, the main shaft, bearings, the bedplate and the tower are basically produced from different types of low-alloy steels and cast irons. The rotor hub is the structure that provides the coupling of the blades, via the pitch bearings, to the main shaft. The main shaft is made of either quenched and tempered carbon steel by means of open die forging, or it can be made of ductile iron, with its surface characteristics treated, for example with coatings. Spherical roller bearings are used with hardened steel grade 100Cr6 and 100CrMn6 and case carburised steel grades. Most turbines above 0.5 MW have two main bearings. The bedplate and the rotor hub are made of low alloy steels, high strength aluminium alloys or ductile cast irons. The production processes used are continuous casting, controlled rolling, forging and welding [JRC, 2012c].

Large turbines use gearboxes with at least one planetary stage and, in fact, as gearbox sizes increase more and more, double planetary designs are being developed. A planetary drive is extremely efficient to deliver high reduction ratios in a limited space, and to transmit several times the torque of similarly sized, conventional gear units. The standard materials choice for gears is case-carburised steel 18CrNiMo7-6. The structural components such as torque arms and planet carriers are made of ductile iron. Housings are made of highly damping grey iron or the tougher alternative, ductile iron [JRC, 2012c].

Electric generators are basically made of a rotor and a stator. The materials used include magnetic steels and copper for wirings for electromagnet generators and steel, copper, boron, neodymium

and dysprosium for permanent magnet generators. High-temperature superconductor (HTS) generators, still in the development phase, basically use HTS wire and ceramics.

The power converter mostly consists of steel, copper and semiconducting materials at the basic materials level. They form power semiconductors the most popular of which for power converters is the insulated-gate bipolar transistor (IGBT). Power converters are highly modular which permits redundancy, an important element to improve reliability of wind turbines.

The foundation of a land-based wind turbine typically consists of concrete, iron for reinforcing bars, and steel ferrule used to connect and support the turbine tower.

In a system as complex as a modern wind turbine, there are many other materials used in smaller quantities and their availability and price evolution may eventually be a more significant cause of concern for the wind industry than the materials used in the greater quantities. Also, the details of the use of materials are also highly dependent on the wind turbine configuration. For example, the permanent magnets in PMGs replace the copper windings used in the rotor of electromagnet generators. This obviously reduces the quantity of copper used *provided that both generators have the same speed and power rating*<sup>6</sup>, but also introduces new materials, such as rare earth elements. Also, low speed PMGs need a significantly higher amount of permanent magnets than medium speed PMGs, but in a trade-off, they don't have a gearbox, thus eliminating the corresponding materials.

There are several challenges related to the use of materials in wind energy that need further research and development. Wind turbine life-cycle management is required for a holistic view of the material flows from raw materials extraction to product end-of-life management. Existing processes may need to be adapted as new materials, including nanomaterials, new fibres and polymers, lubricants and permanent magnets are increasingly adopted.

With a high dependency on imported raw materials, resource management becomes essential in Europe in order to either secure sufficient supply of critical materials for low carbon energy technologies, including wind energy technologies, or to develop alternatives for these materials.

With the technical developments in wind turbines and the efforts to reduce the total weight of the nacelle, new materials may play an important role. New materials may also contribute in making innovative solutions technically feasible and improve reliability in extreme weather conditions such as offshore and in cold climates.

## 2.2. Technological developments

The main driver for developing wind technology is to minimise the cost of energy (CoE) production, for which efforts focus on minimising capital and operation and maintenance costs and maximising reliability and energy production. These drivers translate into: design adapted to the wind characteristics; grid compatibility; aerodynamic performance; and adaptation for offshore conditions. Technical considerations that cover several of these goals include turbine weight reduction; larger rotors and advanced composite engineering leading to higher yields; and design for offshore installation, operation and maintenance [JRC, 2011a].

Throughout the years the electricity grid codes in the EU Member States (MS) have become stricter and now require that wind turbines highly support the grid by having, for example, fault ride-through capabilities and a high-quality electricity output. This, along with the pursuance for increased wind uptake efficiency, caused an evolution of wind turbine technology from fixed to variable rotor speed; from stall control to blade-individual pitch control; from low output control

---

<sup>6</sup> Comparisons are not possible if the generators have different speed or a very different power rating. For example, a 3-MW high-speed EMG has approximately 800 kg of copper per MW which can be compared with 2.1 t/MW in the case of a 3.3-MW low-speed PMG (weight 70 t of which 10 % is copper) [JRC, 2012c]

(no converter) to full output control (full power converter), and so on. See Figure 2 for a snapshot of the market share of turbine configurations that reflect this technological evolution: the market share of types C and D configurations increased from 44 % of installed capacity in 2000 to 84 % in 2009 [Llorente Iglesias et al., 2011].

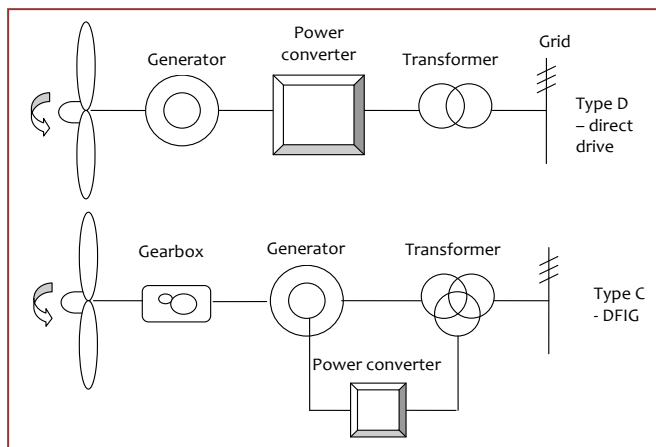

Figure 3: Sketch of drive-train differences between turbine configurations types C and D.

The production of the magnetic field in wind turbine electricity generators is the object of another key technological evolution, from electromagnets to permanent magnets. The former included simple squirrel-cage (SCIG) and then wound-rotor (WRIG) induction generators, then compact DFIG, and full-size, low-speed electromagnet generators (LS-EMG) in a turbine without a gearbox. New designs are substituting electromagnets with permanent magnets (PMG) on the grounds of increased reliability, higher partial-load efficiency, and more flexibility of integration with compact gearboxes or power electronics.

The trend towards ever larger wind turbines continues. The largest wind turbine now in commercial operation has a capacity of 7.5 MW, and most manufacturers have introduced designs of turbines in the 4 – 10 MW range (up to a total of 43 different designs) mostly for offshore use. Table 3 includes a sample of current or recently-presented large turbines, whilst 10 MW designs have been presented by Sway (Norway) and AMSC Windtec (US-AT). Both industry and academia see even larger turbines (10 – 20 MW) as the future of offshore machines [TPWind, 2010].

Manufacturer	Model	MW	Technology	Status
GE Energy	4.1-113	4.1	LS-PMG	Prototype installed in H1, 2012
Gamesa	G136-4.5	4.5	MS-PMG	Prototype installed in 2011
Sinovel	SL5000	5.0	HS-DFIG	Commercially available
Goldwind/Vensys	GW5000	5.0	LS-PMG	Prototype installed in 2010
REpower	5M	5.0	HS-DFIG	Commercially available
XEMC-Darwind	XD115	5.0	LS-PMG	Commercially available
Areva Multibrid	M5000	5.0	MS-PMG	Commercially available
Sinovel	SL6000	6.0	HS-SCIG	Prototype installed in 2011
Goldwind/Vensys	GW6000	6.0	LS-PMG	Prototype expected for late 2012
United Power	UP6000	6.0	HS-DFIG	Prototype installed in Nov. 2011
Siemens	SWT-6.0-154	6.0	LS-PMG	Prototype installed in 2012
Alstom Wind	Haliade 150	6.0	LS-PMG	Prototype installed in 2012
REpower	6M	6.15	HS-DFIG	Commercially available
Enercon	E126-7.5	7.5	LS-EMG	Commercially available
Vestas	V164-8.0	8.0	MS-PMG	Prototype expected for 2014

Table 3: A sample of large wind turbines in the market or being introduced. Acronyms used: PMG = permanent magnet generator; EMG = electromagnet generator; DFIG = doubly-fed induction generator, a type of EMG.

LS/MS/HS=low/medium/high speed; LS is necessarily a direct-drive machine, HS involves a 3-stage, conventional gearbox and MS involves 1- or 2-stage gearbox.

Rotor diameters which, in general stabilised since 2004 at around 100 m, have, during the last two years, started to grow again and nowadays a significant number of turbine designs include rotors with diameters greater than 110 m. Figure 4 shows a comparison of rotor diameters (m) with the electricity generator rated power (MW) for 463 turbines rated 1 MW or larger in commercial operation, prototype or presented.

Figure 4 shows as well an interesting effect, namely that a given rotor is used in turbines with a wide range of power ratings. For example, rotors with a 115-130 m diameter are used in turbines rated from 2 to 7.5 MW. The main reasons for these wide options are commercial, e.g. diversification of turbines to adapt to local wind conditions.

The higher the blade tip speed the more energy can be extracted from the wind – but the noisier this becomes. For this reason turbines might have to operate at reduced speed in noise-sensitive areas. However, offshore, the tip speed can increase above the standard land limit of 80 m/s, thus increasing electricity production.

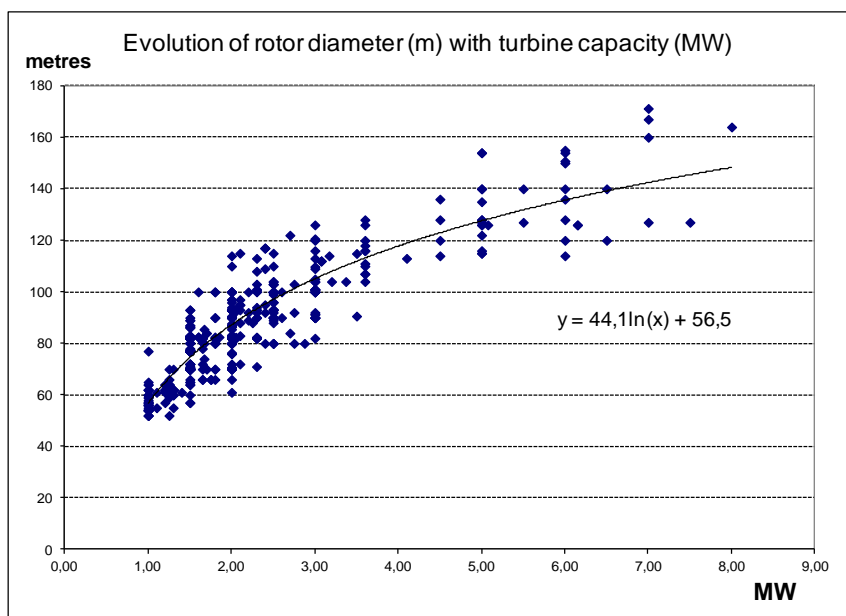

Figure 4: Comparison of rotor size with turbine rated capacity. Source JRC [2012a]

Two key trends in turbine development are towards weight reduction of drive trains and, in general, of the top head mass<sup>7</sup>, towards taller towers onshore. However, offshore turbines tend to stabilise hub heights at 80 - 100 m. This is because offshore wind shear is lower and there is a trade-off between taller towers yielding slightly higher production but needing heavier, increased foundation loads involving higher tower and foundation costs [EWEA, 2009].

Mainly because of costs, offshore foundations for deeper waters (30-60m) are expected to diversify away from monopile steel into multi-member (jackets, tripods) and innovative designs.

### 2.2.1. Blades

As described in section 2.1.3, blades are made of three main kinds of materials, and the shares of the materials are: (a) fibres (55% in a standard blade) and (b) resins (30%) play a functional role, whereas (c) balsa wood, polyester foam and/or steel (8%) play a structural role. In addition, an auxiliary role is played by coatings, steel (e.g. in bolts) and adhesives (7%).

<sup>7</sup> The top head mass (THM) is the weight of all the elements mounted on the tower: rotor (including blades) and nacelle with all its components (drive train, generator, yaw system...)



As shown later in Table 19 (in section 4.2.1), the cost of blades is about 15 – 23 % of the total cost of the turbine<sup>8</sup>, the upper range is increasingly common due to new turbine models with larger rotors. Blades need to reduce their cost and become lighter while increasing stiffness – in some cases the materials already exist but they are too costly. R&D should aim at breaking the trade-off between cost and performance. In effect, lighter materials than glass fibre, such as carbon fibre or thermoplastics, are currently too expensive or have not reached the necessary stage of development. Solid improvements to blade performance and weight will result from the interaction of three factors:

- Better understanding of the loads suffered along the blade (which will lead to design optimisation),
- New or optimised materials (nanomaterials, fibres and polymers), and
- The design of aerodynamic shapes better adapted to the function of collecting energy from the wind.

Together, they will facilitate longer but lighter blades that use less raw materials and are more efficient. In addition, weight reduction in blades causes a chain of materials reduction throughout the turbine nacelle, tower and foundations, all of which contribute to lower overall costs and shield the technology against the risk of future increases in raw materials costs. Also, taller towers provide those larger rotors access to areas of higher, less turbulent winds which reduces loads, increases energy yield and reduces maintenance costs per unit of output.

Another design option is making blades modular. They ease transport issues and enable larger wind turbines to be installed on inland sites. Modular blades are already in use by at least two turbine manufacturers (Gamesa and Enercon).

Nowadays utility-scale turbines are much less noisy than in the past, yet noise is always an important issue where there is still room for improvements. For example, coatings could further smooth wind friction and its corresponding noise generation, thus allowing higher tip speeds. Possibly, these coatings will be based on nanoparticles.

Finally, blade manufacture needs to have a higher level of automation. Here the industry is looking at the automobile industry and its historical process of automation.

### 2.2.2. Gearboxes

Gearboxes are seen as the least reliable part of the traditional wind turbine configuration. Several studies including the European project Reliawind concluded that the electrical systems (including the power converter) and the pitch system cause more failures and higher downtime than any other turbine sub-assembly [Wilkinson, 2011].

In addition, research is showing that gearbox failures are most often due to unexpected loads originating somewhere else, e.g. in the turbine rotor or in its control system as a consequence of forcing the generator to maintain grid frequency. More detailed data are needed to improve the designs. Sensors originally from the automobile industry are now available which can be used for this. System aspects which protect the gearbox and lengthen their life include using a full converter which reduces grid-induced loads or individual-blade pitch feeding which reduces loads when the blades reach the extreme positions (vertical up or down).

New gearbox designs aim at lighter gearboxes, more reliability and more efficiency to reduce both CapEx and OpEx. For example, bearings that are reinforced at the exact points where they

---

<sup>8</sup> A detailed cost breakdown is included as Table 19

support the highest loads and better transfer of loads to the tower (thus by-passing the gearbox), also help in improving gearbox reliability.

### 2.2.3. Electricity generators

Wind turbines that contain rare earths have them mostly in the permanent magnets of their electricity generator, where they make up 30 to 32% of the mass in the magnets. During 2011 wind turbines with permanent magnet electricity generators (PMG) covered approximately 21% of the world market [BTM, 2012]. The other 80% were electromagnet generators which use copper windings and an electricity current to generate magnetism.

The amount of magnets used in PMG is quite diverse and depends heavily on the speed of the generator. Extending the data in Table 1, taking as a reference a 3-MW PMG, if it is low-speed it would use approximately 650kg of magnets per MW; being medium speed it would need some 160-200 kg/MW, and the high-speed version approximately 80 kg/MW. The maximum share of low-speed PMG in the 2011 wind turbine market is about 14% or 6 GW out of 41 GW installed [JRC, 2012a]. Based on these figures and on installations of PMG wind turbines, JRC estimates suggest that between 3 400 and 4 000 tonnes of permanent magnets were used in wind turbines installed in 2011 in the world, containing between 1 100 and 1 300 tonnes of rare earths.

There is a trend to a larger variety of generator designs with a higher share of PMG. PMG are more efficient than the traditional doubly-fed induction generators (DFIG) at partial loads, and turbines generate electricity at partial loads most of the time. PMG have fewer moving parts than DFIG and moving parts are the ones which require more maintenance, thus the evolution from DFIG to PMG is expected to continue which would reduce O&M costs.

The main problem faced by a PM is the high variability in the price of its basic elements, namely the rare earths needed to manufacture permanent magnets, mostly neodymium and dysprosium. The latter increased in 2011 to reach more than 20 times above their previous 5-year average. Also, there is an inverse relationship between operating temperature and magnetic power, and a direct relationship between operating temperature and cost. This in turn affects the design of the wind turbine: by introducing a cooling system in the turbine the magnet specifications (called grade) can be lower and the cost of the PMG may be reduced. But there is a trade-off: a cooling system uses electricity during the whole turbine life.

A further problem with rare earths is the double risk associated with the high geographical concentration of the supply of rare earth elements with about 97% of them extracted in China. On the one hand the risk of supplier market power, on the other hand the experience in certain manufacturing steps currently lies nearly exclusively with Chinese companies.

Further spread of PMG requires better-performing magnets, particularly at higher operating temperatures, this will allow further reductions in PMG size and thus in nacelle weight, and will have a positive knock-on effect on tower and foundations. For this, new permanent magnets are necessary which overcome the physical limits of the NdFeB structure.

A technology which has the potential to achieve these improved specifications is high-temperature superconductor (HTS). This technology is of interest not only for wind turbines but for the whole of the power sector and in particular for grids. For this reason HTS is being researched intensively and even a prototype was being developed as part of the FP6 European project HYDROGENIE<sup>9</sup> [Bannigan, 2011].

---

<sup>9</sup> [http://cordis.europa.eu/projects/rcn/80115\\_en.html](http://cordis.europa.eu/projects/rcn/80115_en.html)

PMG-based electricity generators are increasingly being integrated with a medium or high-speed gearbox and/or with the power converter, thus reducing weight.

***The rise of the popularity of permanent magnet generators***

Developments during the last years have highlighted a trend to an increasing share of permanent magnet electricity generators (PMG) in the future wind turbine market.

Three major elements suggest this trend:

- The analysis of turbine prototypes introduced or announced to be introduced in the period 2011 - 2013,
- A turbine model is sold during approximately during 10 years, and
- The reduction in price of rare earths since summer 2011, along with the projections of abundant supply from 2014 (Nd) and 2017 (Dy) [Hatch, 2011].

Figure 5 shows how the share of prototypes introduced from 2000 to 2013, both completely new designs and new, updated versions of existing designs. The figure shows that whereas in the first four years of the century few turbine designs included PMG -average share of 5%-, during the last four years under study this share has grown to 35%. In absolute numbers whereas PMG were included in 1 - 2 turbine prototypes per year in 2000-2003, during 2010-2013 they were included in 11 - 13 turbine prototypes.

Figure 5 shows as well that the share between low-speed, direct-drive PMG and medium- and high-speed PMG in the last four years of the period studied (2010 – 2013) is approximately equal.

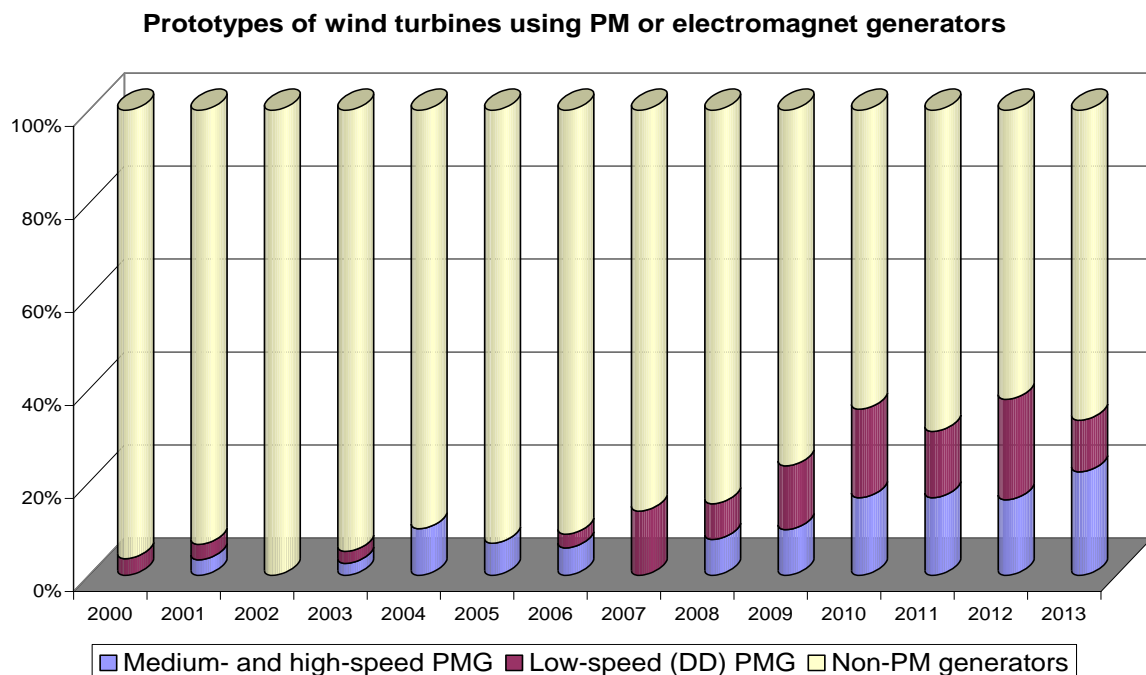

Figure 5: Evolution of share of PMG in prototypes of turbines 2000 - 2013. Source: JRC database of wind turbines.

However, the analysis of the turbine models presented suggests that it is among the offshore turbine prototypes that DD-PMGs prevail over MS/HS-PMGs. Furthermore, it is the models with more significant expectations for future offshore installations (period 2015-2020) that are DD-PMG: Alstom's Haliade 150, Siemens SWT-6.0-154 and XEMC-Darwind / Vensys-Goldwind. The consideration of "more significant expectations" is based on the supply contracts already signed in Europe (e.g. for Alstom, Siemens) [JRC 2012b] and the prospects for cost

reduction after its manufacturing origin in China (XEMC, Goldwind). Significant, non-DD prototypes offshore include some by Vestas, Gamesa, Bard, REpower, Sinovel and Areva.

Wind turbines with electromagnet generators are currently predominant onshore, e.g. those by Vestas, Alstom, Enercon, REpower, General Electric, Nordex, Suzlon and Sinovel. The share of PMG in turbines onshore are nowadays slightly more significant worldwide than in Europe and the analysis of new designs suggest that the penetration of PMG onshore will continue to increase in Europe as in the world.

Taking into account general wind energy deployment scenarios (see subheading 3.6), the advances expected in the different electricity generator technologies and other factors, Table 4 shows a breakdown per technology of the projected installation base by 2020 and by 2030.

European annual market share	GW	Generator technology split				
		EMG-g geared	EMG-DD	HTS	MS/HS-PMG	DD-PMG
By 2020	14	32%	12%	1%	24%	29%
By 2030	13.5	0%	10%	18%	28%	44%

Table 4: Breakdown of wind annual installations by electricity generator technology, 2020 and 2030, in the JRC deployment scenario. Source: JRC [2012a]

#### 2.2.4. Power converters

The most common type of power converter is used in turbine configurations with DFIG because only about one third of the total electricity generated needs to pass through the converter. Full power converters, controlling all electricity generated, are three times as expensive. Yet, under certain configurations (e.g. direct-drive) a full power converter is indispensable.

Power converters are made of power electronics, and are one of the main causes of failures in wind turbines. In order to improve their failure rate, power electronics need more and better testing to simulate the dynamic behaviour of the wind turbine, and correspondingly design and material changes to improve their specifications.

A design option to improve the reliability of the converter is the redundancy of power transistors (IGBTs): in a two-module converter where one of the modules is unserviceable the other one can treat 70% of the energy. A second option is to use higher-temperature elements such as condensers and IGBTs, but the cost of these have to decrease to allow for widespread use.

Specific challenges for the IGBT include its relatively short useful life (around 5-10 years), relatively low power (a maximum of 1 MW), relatively low junction temperatures (150 °C for the state-of-the-art); and rated low voltage (below 1000 V). Solutions could come from the use of silicon carbide (SiC) as base material for IGBT SiC has the potential to dramatically increase the power density of the power converters.

#### 2.2.5. Towers

As discussed later in section 4.2, the cost of towers is about 16 – 26 % of the turbine's total cost, the upper range applies mostly in low-wind turbines whereas offshore turbines do not need to be so high.

Most wind turbine towers are made of steel although there is a low but increasing number of manufacturers installing pre-stressed concrete and hybrid towers, e.g. Enercon, Acciona, Areva, Siemens and others. The choice depends on the technological background of the turbine manufacturer, on the relative cost of concrete and steel, on the design height of the tower, on logistics and, increasingly, on a minimum local content (a percentage of locally-fabricated turbine

content) imposed in certain countries. Above 100 m of height costs and ease of transport make concrete and hybrid towers a better choice than tubular steel, and with increasingly taller tower installations the trend is towards more concrete in towers.

A steel tower is made of 20-25 metre-long sections, the base being wider, thicker and shorter due to its weight. Inland transport of the larger sections limit the size of steel towers: 4.5m is the practical limit for the diameter of complete ring sections that can be transported along public highways [Gifford, 2007]

Weight in tonnes	Concrete tower		Steel tower	
	70m, 2MW	100m, 4.5MW	70m, 2MW	100m, 4.5MW
Turbine height and rating	70m, 2MW	100m, 4.5MW	70m, 2MW	100m, 4.5MW
Tower head mass (THM) inc. rotor and nacelle.	105	220	105	220
Tower stem	450	1050	135	240
Total mass	555	1270	240	460

Table 5: Comparison of gross mass for onshore (2MW) and offshore (4.5MW) turbines. Source: Gifford [2007]

Lattice towers are more common for small turbines but only Fuhrländer<sup>10</sup> offered them for large turbines.

Cost issues dominate the trade-offs in both materials and design: a higher-specification steel grade reduces the amount of steel needed (but it is more expensive), whereas tower design can reduce steel use through thinner walls which is possible with larger tower diameters.

The strength of the steel plate is weakened when welding the internals (i.e. the elements that go inside the tower: ladder, lift, cables, etc.). Then a margin of extra plate thickness is necessary in order to maintain the same mechanical properties. Therefore the replacement of welding is a way to reduce that margin and thus the steel use in towers. Vestas claims to have succeeded in replacing welding with permanent magnets which saves 10 t of steel for the 84-m tower of a V112-3.0MW [Vestas, 2012].

Hybrid concrete-steel towers are reaching new heights with companies building 145 m towers, and claiming that up to 165 m is possible. Innovative, better-performance mortars are needed that can be worked out over a large range of temperatures, very liquid but of quick hardening and of high strength and other improved specifications. These mortars, used to join in situ the pre-cast concrete parts of the tower, would reduce costs through e.g. reduced building time [JRC, 2012a].

### 2.2.6. Offshore wind: farther and deeper

Figure 6 shows the mean depth<sup>11</sup> of existing and planned<sup>12</sup> European wind farms based on the 4COffshore wind farms database [4COffshore, 2012]. Denmark, the Netherlands and Sweden were the first European countries to build demonstration offshore wind farms starting in the 1990s. However, the timeline starts only at year 2000 to give more space in the graph for the major cluster of offshore wind developments, starting around 2005. For the same reason, the wind farms developed or planned for waters deeper than 150 m have been omitted in the graph. Those include one wind farm in Norway in 2012 and two wind farms each for Croatia, Estonia and Spain planned for the period 2015-2020. Currently Germany and the UK have the highest numbers of planned wind farms.

<sup>10</sup> Fuhrländer is a German turbine manufacturer that filed for insolvency in September 2012.

<sup>11</sup> Mean depth is calculated from the minimum and maximum depths estimated from nautical charts.

<sup>12</sup> Data up to 2011 can be considered as existing wind farms whereas data from 2012 onwards reflect planned wind farms, with increasing uncertainty especially beyond 2020.

Although most future wind farms remain at a maximum depth of 50m, there is a significant number of projects planned for deeper waters at 50-350m depth. By 2012 three wind energy projects have been built on floating substructures, in waters deeper than 50m: a 2.3 MW turbine at a depth of 220 meters off the coast of Norway (Hywind), a 2 MW turbine at a depth of 50m off the coast of Portugal (WindFloat) and an 80 kW turbine at a depth of 113 meters off the coast of Brindisi in Italy (Blue H).

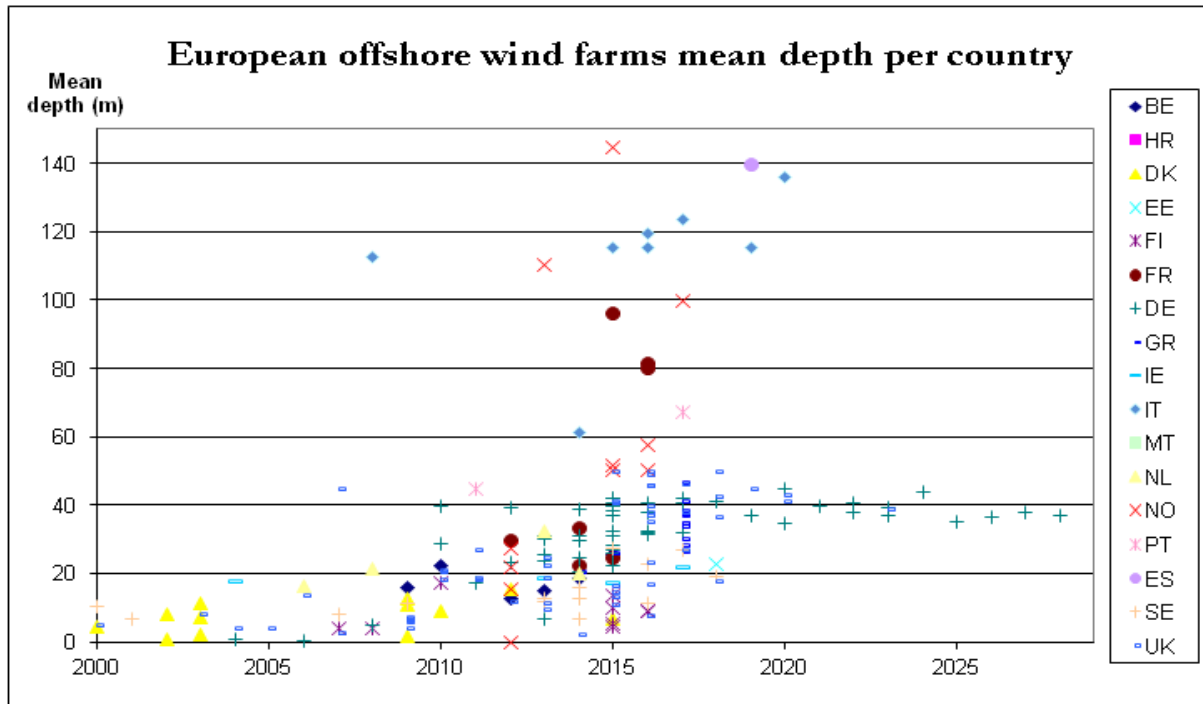

Figure 6: Mean depth of existing and planned European offshore wind farms. Source: JRC based on 4COffshore [2012]

However the majority of future wind farms are still planned to be erected at a distance of less than 50km from the shore. In addition, both Germany and the UK have consistently placed all of their planned wind farms in maximum 50m deep waters. Norway, on the other hand, plans to go the deepest with wind farms at several hundred meters depth, while staying relatively close to the shore.

A general trend of going to deeper waters – especially where shallow waters are not available – has been observed but this trend is counter-balanced by the related increased technical demands and according to Deloitte [2011], this will lead to an upward trend in offshore project costs during the next 10 years.

### 2.2.7. Offshore support structures.

The most popular offshore foundations until now are the steel monopile foundations, followed by concrete gravity base. Gravity foundations are floated to site then flooded with water to sink, then filled with sand. They require a flat seabed but achieving this is not very problematic. Monopiles are drilled or hammered into the seabed, the former is less noisy and the latter is cheaper. Given that marine noise has a strong –albeit temporary– effect on marine life, new ways to drill monopiles are needed that reduce cost while maintaining low noise levels.

At the end of 2011 among the 4 416 MW of offshore (including intertidal) installed wind power capacity registered in the JRC database, monopile solutions represented 70 % of the total, 14 % were gravity-based, 7.7 % the multi-pile solutions used in China, and the remaining 8 % were jacket, tripod, tripile and other structures [JRC, 2012a].

Foundation	MW	%	Foundation	MW	%
Monopile	3 092	70.0%	Tripile	85	1.9%
Gravity	626	14.2%	Tripod	30	0.7%
Multi-pile	338	7.7%	Floating	4.3	0.1%
Jacket	241	5.4%	Total	4 416	100%

Table 6: Split of world offshore installations by foundation type. Source: JRC database

As turbines get larger and installations reach deeper waters monopiles lose (economic) grounds in favour of jackets. However, there is still a need for cheaper foundations whose manufacture can



Figure 7: Twisted Jacket foundation, supported by the UK CT OWA. A prototype was installed to support the meteorological mast at the Hornsea future offshore wind farm. Drawing courtesy Keystone Engineering

be automated using standard elements, which can be transported and installed more economically. However, a strong barrier is that it takes several years for a new design to reach market acceptance. Jacket foundations are an example of this: the two first used in an offshore wind farm were installed in 2007 (Beatrice Demonstration, UK), and despite their track record in the oil and gas industry it was only in 2011 that a full-size offshore wind farm used them (30 units at Ormonde, UK)

Neither jackets nor tripods are currently built in serial production, which suggests limited possibilities for cost reduction. New designs include self-installing foundations, suction buckets, twisted jackets and others. The Offshore Wind Accelerator (OWA) of the UK’s Carbon Trust has been instrumental in bringing some of these new designs onto the demonstration phase such as the twisted jacket (see Figure 7).

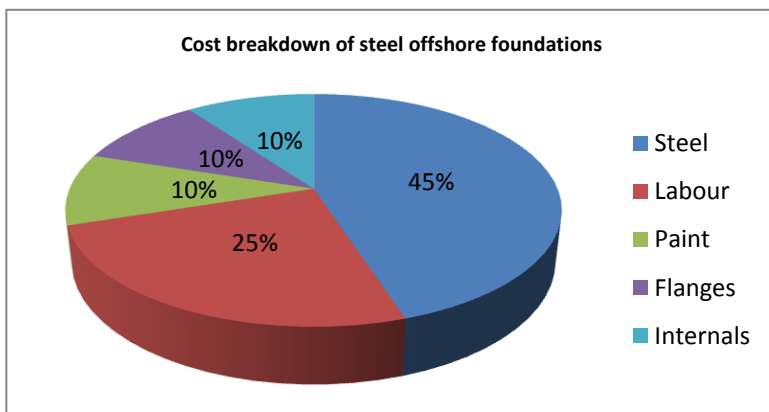

Figure 8: Cost breakdown of materials and labour in steel foundations. Source: Dziopa [2012]

An approximate breakdown of materials and labour costs for steel foundations, whether monopile, jackets or other is shown in Figure 8. The split does not include overheads nor plant depreciation, which should be added.

The current development of floating foundations include spar-buoy and multi-column, semi-submerged structures.

There is room for learning-by-doing cost reduction for the fabrication of offshore foundations and for the installation of cables, turbines and foundations, with some industry insiders expecting significant reductions within 2 – 3 years. The optimisation of procedures and technologies which at times were originally designed for other industries would also lead to cost reduction. One example is the electrical connection of array cables to the turbine through its foundation.

## 2.3. Current challenges and possible bottlenecks

This section analyses challenges from three points of view: technology, project management, and the wider context

### 2.3.1. Technology challenges

The overall challenges for the materials used in wind energy that need to be addressed through research and development are [JRC, 2012c]:

- Life cycle management, from ore processing until waste reuse and recycling. This needs to be done by means of environmentally-friendly production technologies. In many cases existing processes need to be adapted.
- Resource management: Europe being a continent with few raw material resources should assure its strategic access to these products and/or develop alternatives for the critical materials,
- New materials (e.g. nanomaterials, fibres and polymers for blades, lubricants, permanent magnets) which make innovative solutions technically feasible,
- Materials for extreme conditions of exploitation, such as offshore and cold climate conditions
- Materials which allow and/or facilitate the automation of component manufacture.

Scaling up turbines presents many challenges, one of which is the reduction of the use of materials through better design. However, turbine design requires a systems approach which might not be possible for component manufacturers. For example, a tower manufacturer might innovate a thinner tower design which reduces the cost of materials. However, if a thinner tower causes resonance of the offshore substructure then thicker foundations would be necessary.

The electrical subsystem currently causes the most failures although not necessarily the most expensive ones, both in terms of maintenance needs and lack of energy production (downtime). Their reliability needs to be improved.

Technological improvements will help in reducing the cost of energy (CoE). However, other barriers already prevent a more significant deployment of wind energy. The application of the latest technological evolutions is sometimes restricted by local or country regulations. For example, taller towers and larger rotors are now available which give access to stronger winds resulting in higher energy production and lower CoE, but they are not allowed in certain regions or countries.

### 2.3.2. Project management challenges

The need for collaboration and for early supply chain engagement is stronger in offshore wind than for land projects. The different actors that intervene in an offshore project should start discussing the design well in advance, before the project developer has granted the different contracts. Cable manufacturers and installers, the onshore grid operator, foundation manufacturers and installers, designers and builders of offshore substations, turbine manufacturers, geological and geophysical surveyors, met mast suppliers, and other actors should be involved before key decisions have been taken. The industry has described plenty of examples when failure to have the right information results in problems and extra costs, and even minor adjustments are no longer possible. For example, at one particular wind farm, four of the 30 turbine positions were planned for water depths too shallow to allow a jack-up vessel capable of lifting the nacelles and piles to access the site, and the successful bidder only realised after the



award. Eventually a solution was developed but this imposed an extra cost that could have been avoided if the contractor was involved before the layout decision [Balmer, 2012].

### 2.3.3. Challenges of the context

Long-term planning by local and national authorities is essential to overcome barriers. For example, the experience of countries with high wind installed capacity is that later phases of development have to correct situations created in earlier ones. This applies in particular to the siting of wind turbines in a random way, e.g. in “the backyard” of their owner. As the number of turbines grows, a chaotic scenery can be created which prompts some spatial planning authorities to limit further deployment. The solution to this problem is a more careful spatial planning that is long-term thinking. National authorities could define long-term goals to reach the maximum country potential (and a regional breakdown), and which take into account expected technology evolution, and spatial planning authorities could then define the areas where turbines would eventually be located.

National and regional authorities could also streamline the permitting process so that costs to the developers are reduced by improving the efficiency of the process and obtaining synergies. For example, for prospective offshore developments the authorities could, in agreement with developers, set up wind measurement equipment ahead of the consent process so that longer-term data are available which reduce the uncertainty of energy production. With less uncertainty developers can obtain better loan conditions.

Box 2: what is the future of the remuneration schemes?

High shares of variable renewables push down wholesale market prices. Grid parity in particular make possible a scenario of high renewables penetration, when a windy/sunny day results in high wind/solar electricity generation and producers, if they received the market price, fail to recover investment because of the very low marginal price caused by the wind/solar resource.

This problem is not presented yet because variable renewables receive a feed-in tariff that is mostly independent from the marginal price. However, with further reductions in wind CoE there will be more pressure on governments to reduce or stop feed-in tariffs.

Many solutions could be explored, including the setting up of an average price for variable electricity that is linked to the market price but not strongly affected by the volume of variable renewable electricity in the market. This issue will become more and more important with increasing renewables market share.

Another aspect likely to reduce the CoE without impacting public budgets is the reduction of risks and risk perception. In effect, the interests borne by developers on the borrowing which cover capital costs are, in particular for offshore wind, strongly affected by the risk perception that lenders have of the regulatory framework. Where the perception is of regulatory insecurity, i.e. that the government can change the way wind electricity is paid for (e.g. feed-in-tariffs) retrospectively, as it recently happened in Spain, lenders require higher interest rates and developers require higher returns on investment.

The market uptake of innovative offshore foundations is affected by the long time that it takes for a new foundation to get established commercially (see section 2.2.7). To accelerate this process public support is necessary for full-size tests of new foundations and/or first-of-a-kind use in a new wind farm. Initiatives such as the European Energy Programme for Recovery (Offshore Wind Energy) did just this, e.g. at Thornton Bank offshore wind farm [EC, 2012].

The uncertainty over the future size of wind turbines (5 or 10 MW) and of future foundation types creates a problem for port development. Monopiles, caissons or tripods, all have very different port requirements, and it is hard to justify developing dedicated port facilities until those uncertainties are reduced. Over the past year the situation has become much clearer and as the wind farms have gone from tens of turbines to several hundred, at last it is possible to foresee dedicated port facilities being built. It is very likely that two or three such facilities will be built along the European coastline to supply both Britain and other European needs [Balmer, 2012].

Earlier wind turbines could be installed by using modified existing jack-up vessels. They were at their limit and could only really install about 30 turbines per season. For the current wind farms (farther offshore, deeper waters, and larger turbines) specialised vessels have come into play which are much more capable, but still scarce and cost significantly more to build and operate. As expressed by Balmer [2012], “building a ship as capable as the current A2SEA vessels (built for 2.5 to 3MW) for a 6 to 7MW size would require a really big increase in CapEx over the current vessels. Investors would need the assurance of three or more years of constant work at say 100 or more turbines a season before they could justify starting building one”. Table 7 shows CapEx of recently-ordered installation vessels:

Company	Vessel	Cost	Delivery
A2SEA	SEA Installer 2	USD 155 M	2014
Seajacks	Seajacks Hydra	USD 121 M	2014
RWE Innogy	Friedrich Ernestine	EUR 100 M	2012
Seafox/Keppel	Seafox 5	USD 220 M	

Table 7: Examples of recently-ordered installation vessels. Source: company press releases

Installation vessels are no longer seen as the bottleneck. “Cables manufacturing and cable-laying vessels are one of the bottlenecks today, and manufacturing of jacket foundations is likely to be the next one. The factories to make these take a lot of space (including vertically, which has very permitting and local consenting issues) and are neither cheap nor quick to build. They need to be built by the sea, and harbour space is in short supply in the UK - and expensive as more profitably used for other activities” [Guillet, 2012]



Figure 9: Loading the Sea Energy (A2SEA). © Jos Beurskens

Offshore array cable is currently rated at 33 kV, and if increased to 66 kV (the equipment rated at 72 kV) they could host more turbines. For this, standard equipment needs to become available.

Strongly depending on thermal conditions, a 33-kV cable can connect 3 – 4 turbines at around 36 MW, whereas a 66-kV one can connect 10 turbines at around 70 MW. 66 kV arrays will require

new ways of connecting because the voltage level is not standard for this kind of (offshore) connection. Existing cable and installation methods offshore are not certified for 66 kV, but whereas cable connection is standard, offshore switchgear is under development and it could take 1 – 2 years to reach full commercial development [JRC, 2012a; Dong Energy, 2012].

Floating foundations of the spar-buoy type face the challenge of a too high steel cost.

The availability and cost of certain raw materials, rare earths, has given place to two major technology decisions among OEMs: whether to use permanent magnet generators or not and whether to use them with or without a gearbox. As explained in section 2.2.3 electricity generators have very different demand of rare earths depending on whether they are low-, medium- or high-speed. If the rare earths problem is considered very serious the OEM might decide not to take risks at all and stay with electromagnet generators. However, it might also consider that if its demand is low (which is to be achieved by using high-speed PMG), its risk exposure is low as well. Eventually, an OEM might protect itself against scarcity risks in different ways and decide that a low-speed, direct-drive PMG would provide the best commercial results.

As variable renewables increase its penetration of the electricity mix there will be increasing pressure on their integration. The main options to smooth this integration are energy storage, improved interconnections, more flexible conventional power generation plants, and demand management with the support of smart grids. All these options will need to be pursued in parallel because not one of them is the perfect solution and because the electricity system is more robust when it uses a wider mix of both generation and grid management resources.

The European society is still not aware of the full extent of the climate change problem and of the impact of wind energy to alleviate this problem. There is a need for the EU and individual Member States to raise awareness that reduces the “not in my back yard” syndrome toward wind farms and their required grid connections. Last but not least, there is a need for better cooperation among the European wind industry, academia and R&D institutions in research, education and training.

## **2.4. Future technological evolution**

The engine behind European wind RD&D is the European Wind Initiative (EWI) of the SET-Plan [EC, 2007], composed of industry, EU Member States and the European Commission. The EWI has an estimated investment of EUR 6 billion up to 2020 shared between industry and public funding. Its steering group has approved the following R&D priorities suggested by the Wind Technology Platform [TPWind, 2010]: new turbines and components for on- and offshore deployment, large turbines, improved reliability and availability, testing facilities; development and testing of new offshore foundations, mass-manufacturing of foundations; grid integration including long-distance HVDCs, connections offshore to at least two countries and multi-terminal solutions; offshore logistics and specialised transportation and installation vessels, and resource assessment including a new European wind atlas (see box 3 at the end of this section) and spatial planning instruments. While R&D programmes run by the European Commission are already adapting to these priorities, Member States are expected as well to align their R&D funding in the near future.

### **2.4.1. Technology**

RD&D in advanced materials offers synergies with a number of low-carbon industries including: fibre-reinforced composites with the nuclear and solar energy; coatings with the solar power, biomass and electricity storage industries; special concretes with the building and nuclear industries; high-temperature superconductors with the electricity transmission and storage

sectors, etc. Synergies exist as well between the offshore sector and the oil and gas (O&G) industry in areas such as the manufacture of installation vessels. This sector can bring in experience and know-how to the offshore wind sector, in particular on substructure installations and on operation and maintenance issues.

For the time being the largest wind turbines with a working prototype, or deployed commercially, are Enercon's 7.5MW E126 onshore machine (127m rotor diameter) in commercial use, and offshore the REpower 6M (126m rotor and rated 6.15MW) and Siemens' SWT-6.0-154 (154-m rotor and rated 6MW) prototype. Vestas is designing a 164-m rotor machine rated at 8 MW and a number of manufacturers, including AMSC-Windtec, Goldwind, Sinovel and SWAY are known to be working on a 10-MW turbine.

An alternative design around a rotor with a vertical axis, e.g. Vertiwind [Technip] and Aerogenerator X, is meant to have key advantages for larger sizes and in particular for offshore wind farms. The equipment is placed just above sea level which enormously facilitates installation and maintenance. However, no full-size prototype has yet been built.

Turbines with larger rotors are currently marketed for low-wind sites. Their components are designed based on wind conditions which do not put excessive loads on them. In the future larger rotors will be used even for high-wind onshore areas and this will require that their components have been re-designed in order to stand the extra fatigue caused by high loads.

More and more turbines will be designed in families in the same way as in car manufacturing, e.g. mainframes for several models of cars. Series manufacture is necessary so that manufacturing of components and turbines can be more efficient, this could involve significant cost reductions. One example is the automation of blade production.

Some of the technologies currently in the early stages of development such as kites, undergoing slow proof of concepts (e.g. vertical-axis wind turbines, see above), or not even thought of nowadays, could become mainstream in the 2030-2050 period. However, given the uncertainties, these technologies are not considered here.

#### **2.4.2. Project management**

Wind deployment is nowadays based around individual wind turbines added to form a wind farm. However, a system approach in which the "unit" becomes the wind farm will itself become more and more the norm. This "wind-farm thinking" will result in modified turbine design e.g. to share resources. Larger turbines can be designed with medium voltage electricity generators (3.3 – 6kV) and electricity is then exported with significant less losses than at low voltages (690 v). The frequency converter can then be placed outside the turbine and two or three turbines can share a single, modular converter cabin thus achieving economies of scale in both CapEx and OpEx. This cabin can have a controlled temperature thus ensuring a better environment and thus the longer life of power electronics, although this comes at the cost of continuous energy consumption.

The state of research of several key technologies, namely high-temperature superconductor generators and lighter, next-generation blades, suggests a serious possibility that in 10-15 years new offshore wind turbines will weigh similarly to the ones currently being installed at offshore wind farms but with double generator rating and swept area. In this scenario these turbines could use the current foundations and the repowering of the current state-of-the-art turbines will be a serious option. Wind developers should take this into account in the design of offshore connections.

Logistics offshore are less efficient than in the O&G industry. For example, with new wind farms being built further offshore vessels will need to carry more wind turbines in order to do less trips

and to better use weather windows. In addition, they should be able to install both turbines and foundations.

Offshore there is much room for reducing costs by learning-by-doing, even more than from technological innovations. This requires coordination between all actors: OEMs, steel producers, cable installers, etc.

### **2.4.3. The context**

Public bodies could possibly have the largest impact in cost reduction if they focused in reducing the risks and uncertainties existing in the different phases of a wind farm project, or structuring electricity markets so that they are friendlier to variable renewables. Examples of the former include identifying and reducing the uncertainty of wind energy yield calculations (which would result in lower risks for financial institutions providing debt (see box 3 below); examples of the latter include reducing the wholesale market gate, see section 4.2.6.

Also, national authorities could reduce the risks of the permitting process, e.g. through streamlining the permit schemes, public planning of preferred wind deployment areas, etc. Identifying why developers require such a high internal rate of return, and financial institutions require such a high interest rate for offshore wind projects, and subsequently taking action would help to ease the pressure on offshore CoE.

Wind energy is strongly linked to other sectors including the electricity grid, subsea HVAC/HVDC cables and electricity storage. The grid is a fundamental enabler for higher wind penetration but it is currently underdeveloped in particular regarding international interconnections. Storage includes pumped or reservoir hydropower, compressed air, batteries and other technologies that still need very comprehensive R&D. The European installed capacity of hydro-pumping storage, currently at 40 GW, could be increased in order to allow for more system flexibility and to support the 2020 target of 20 % renewable energy in the EU.

Future rotor and nacelle designs will aim to separate load from torque and to conduct only torque to the gearbox whereas load is transferred to the tower. Among other benefits, this will shield gearboxes from unwanted loads which will result in higher gearbox reliability. Several manufacturers are already working on this approach.

## **2.5. Role of European industry on global technology and innovation**

At least three elements shaped the evolution of wind technology innovation in the last years: actors, institutions and interactions [Jacobsson and Bergek, 2004].

### **2.5.1. European actors and institutions.**

Wind technology manufacturers tend to organize their innovation activities in a similar way as science-based companies, according to Pavitt classification [Pavitt, 1984]. The sample of European firms selected for this study includes companies<sup>13</sup> that rely on a balanced portfolio of internal and external research projects. Research activities for these companies are largely in-house driven, and are characterised by intensive patenting activities and a ‘technology race’ that pushes forwards the frontier of knowledge production. Their evolution of R&D expenditure from 2002 to 2011 displays an annual average increase of EUR 90 million. The increase is mainly

---

<sup>13</sup> The companies for the present assessment are Vestas, Gamesa, Siemens, Enercon, Acciona, REpower, Alstom, Nordex, Areva and Vergnet.

attributed to Vestas with EUR 51 million per year. By contrast, Gamesa registers one of the lowest increases of R&D expenditures with an annual average of EUR 1.7 million.

A wind patenting intensity analysis was used to obtain the R&D investment of other major European wind companies. Overall the selected companies accounted for more than 40 % of global supplied capacity (MW) in 2011 [BTM, 2012; JRC, 2012] and 15% of total WIPO wind patent applications. A comparison of the evolution of wind patents versus their R&D expenditure for the above mentioned European companies is displayed in Figure 10.

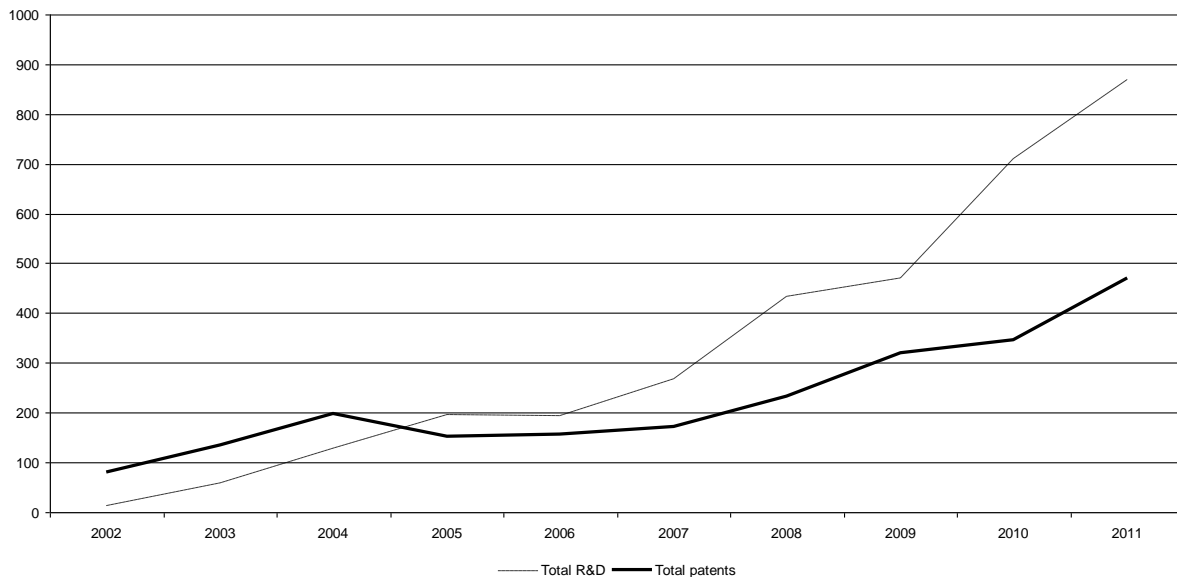

Figure 10: R&D expenditure (*in million EUR*) vs. patent applications (*in numbers*) for selected firms, 2002 – 2011. Source: JRC [2012a]

From 2002 to 2011 an increase of R&D expenditure is accompanied by an increase in patent applications, with a correlation coefficient between R&D expenditure and patent applications of 0.96. However, the ratio of patents to R&D expenditure declined during the period from 6 to 0.54 patents per million euro. Consequently, wind turbine manufacturers find themselves in a situation of diminishing returns from investing in research.

European corporate R&D in the wind sector in 2011 was EUR 870 million, 30 % above the EUR 670 million spent in 2010. In recent years corporate investment for wind technology was higher than public investment [JRC, 2009; JRC, 2012b]. For example, in 2010, the corporate share amounted to 81% of wind R&D investments<sup>14</sup>.

As for the RD&D (research, development and demonstration) investment in the Member States, in 2010 it accounted for EUR 174 million, being highest for United Kingdom (EUR 73.7 million) and Germany (EUR 36.8 million). The correlation coefficient between public RD&D in wind and GDP is 0.48, it is noted that larger economies tend to invest more in wind R&D technologies than smaller ones.

The European Commission, the European Bank for Reconstruction and Development and the European Investment Bank are also involved in financing wind technology development and deployment. Large scale investments are assured through the European banks (loans, RE funds, SEI and TCFP) and European Funding, such as the Seventh Framework Programme, Competitiveness and Innovation Framework Programme (Entrepreneurship and Innovation Programme-EIP and Intelligent Energy Europe-IEE) and regional Policy (ERDF and CF). The

<sup>14</sup> Depending on the country, corporate R&D investment may have two important sources of public funding not discounted in this assessment: (a) tax deductions and R&D subsidies, the latter perhaps as part of a national programme.

budget execution of the major European funding programmes would have potentially gathered for 2010 as much as EUR 1.1 billion as EU investment dedicated to the renewable energy technologies [JRC 2012b]. In 2010, the European Investment Bank signed for EUR 2.19 billion in wind project loans. The high interest for wind development is also manifested through the loans granted by the European Bank for Reconstruction and Development in 2010 (EUR 208 million).

### **2.5.2. International competition.**

General Electric of the US, Goldwind and Sinovel are relevant examples of non-European companies for comparison. GE, who ranked behind Vestas and Goldwind in 2011, invested approximately USD 208 million in wind R&D in 2010, almost 3.45% of its sales. From previous findings characterizing European companies (JRC 2011c), larger and older firms have a higher research intensity than smaller ones. However, this does not seem to be the case for Asian companies. Chinese companies (Sinovel, Goldwind) are younger and smaller than the European or American ones, but lately very successful in the wind business. According to the present analysis, these Chinese companies invest almost USD 47 million in R&D, an amount that represents barely 10% of Vestas' 2010 R&D investment. Nonetheless, their combined revenues in 2010 represent 67% of Vestas' revenues that year. Chinese firms are therefore less R&D intensive but they become increasingly competitive partly thanks to technology licensing from European companies (see section 3.5).

### **2.5.3. Interactions between actors and environmental policies.**

Wind technology companies generally have expertise and ability to work with government or industry regulations<sup>15</sup> and are lobbying their cause in order to change environmental regulations. For example, Vestas and other companies presented several proposals to the head of the states and governments participating to the G20 summit in Seoul, South Korea, in November 2010. In another example, Vestas encourages a fixed CO<sub>2</sub> price and proposes a phase out for governmental subsidies for fossil fuels.

It is interesting to see that the number of Vestas WIPO patents correlates well with European public R&D subsidies, with a 0.99 correlation coefficient. In fact, European wind manufacturers in the selected sample except Acciona and Enercon show a higher sensitivity to European public R&D subsidies than to Asian<sup>16</sup> and American funding: correlation coefficients between the number of their patent applications and European RD&D funds range between 0.75-1.

In the United States, public R&D investment in wind technology was lower than in Europe from 2002 to 2011. In recent years, due to the "American Recovery and Reinvestment Act" (ARRA), the levels of RD&D investments have increased considerably to reach EUR 61.7 million, becoming comparable to the ones in the UK (EUR 73 million).

Wind technology development was also induced by policies to support deployment. Public incentives for wind deployment could be represented by taking installed capacities as a proxy. In 2010, corporate R&D investment in wind reveal to be sensitive to wind installed capacity: the correlation coefficient between corporate R&D in wind technology and the European countries installed capacities is 0.42. The increase in installed capacities in China has had an inducement effect on innovation activities of companies such as Siemens, Nordex, Acciona, REpower systems and Gamesa: the correlation coefficients between the number of patent applications and installed capacities vary between 0.5 and 0.6. The direct effect of favourable environmental deployment policies is reflected in the localization of wind research activities. For example, Vestas and Gamesa opened research centres in Asia.

---

<sup>15</sup> Paul Nightingale, Roger Miller, Joe Tidd and Mike Hopkins *Why Patterns of Technical Change Differ: Further Steps Towards an Integrated Typology*

<sup>16</sup> Japan, South Korea...

Beyond wind, the usual regional distribution of RES R&D investment tends to show that market size matters in the localization and intensity of wind research activities [JRC 2012b].

Box 3: an example of the benefits of R&D investment in reducing the CoE.

A new European wind atlas would bring about the following benefits:

**Reduced financial risk** for investors through reduced uncertainty on the wind resource, and resulting in higher debt-to-equity ratio [Tindal, 2012]. In a simplification the total profit of a wind project is used either to pay debt or to reward equity. Whereas expected profits are based on energy probability 50 (P50, the average level of generation: half of the year's output is expected to surpass this level), loans are based on P90 (90% of the year the output is expected to surpass this level; obviously P50 > P90 in MWh). The closer P90 to P50 (i.e. higher P90/P50 ratio) the higher percentage of CapEx will be financed by debt, and the less capital needed from the project owner. With less capital needed, owner receives a higher internal rate of return (IRR, %) and part of its capital is released for other projects. The following table gives figures for a 28 MW (39 M€) onshore wind farm:

P90/P50 Ratio	Investment required	IRR (%)	IRR (€)	Money for next project
80%	€9.5m	13.6	1.3m	€0
83%	€8.0m	14.3	1.1m	€1.5m
87%	€6.5m	15.7	1.0m	€3.0m
90%	€5.5m	17.1	0.9m	€4.0m

These results show that the reduction of the uncertainty on the energy production from 20% to 10% (the leftmost column), then the IRR will increase from 13.6% to 17.1% and € 4m are released for another project

A real case from a wind farm in Germany has turned into a court case (The Watzertal Park, <http://www.domstol.dk/VestreLandsret/gruppe/Pages/WatzertalParken.aspx> (in Danish)). The case is about a 40 M€ wind turbine park, where the owner is suing the developer of the park for misleading information about the wind resources. These kinds of court cases are quite common, and often the source of the dispute is inadequate or too uncertain wind resource estimation.

**Reduced development time and more focused, on-site measurements.** At present it is always recommended to erect a mast on the potential wind turbine site and let it measure for a few years. This is recommended simply because the meteorological wind resource models are too uncertain to use without any experimental confirmation, with the adverse consequences mentioned above. More reliable models could reduce both the number of masts and the period necessary for the measurements, or eventually eliminate the need for measurements altogether (e.g. for small wind farms). This would certainly reduce the time spent for feasibility studies, which for offshore parks can be as high as 5 years.

**More optimised wind turbine design.** More detailed wind conditions (turbulence, wind shear, etc.) in some of the most representative geographic conditions can help developing future designs of bigger turbines (modelling of aerodynamics, loads on bigger blades, rotor and blades control) in remote rough condition areas (offshore, cold climates, storm conditions).

**Operations and maintenance.** Models provided by the Atlas can be used for assessing impacts (wear & tear, fatigue, control strategies) on existing assets in case increasing production is required.

**More efficient layouts.** The first layout for an offshore wind farm is often based on current knowledge of market, and perceived restrictions. After permits are granted, there is an excellent opportunity to optimise the wind farm layout based on known restrictions and updated knowledge such as wake effects, turbulence, etc. In a recent paper presented at the EWEA 2012 conference Anthony Crockford and co-authors from the large wind consultancy firm Ecofys show that for an 132MW offshore park close to the Netherlands, a reduction of the cost of energy of 10% (!) could be obtained through optimization of the park layout.

**Better forecasting.** A report by Gregor Giebel summarises the economic benefits from short-term forecasting. Going from expecting the winds tomorrow to be as today (persistence) to a perfect forecast would increase the value of wind power from somewhere between 0.03 and 0.3 €/kWh. This is a lot of money, see chapter 7 of the report: Second version of State-of-the-Art in Short-term Prediction:

[http://www.prediktor.dk/publ/GGiebelEtAl-StateOfTheArtInShortTermPrediction\\_ANEMOSplus\\_2011.pdf](http://www.prediktor.dk/publ/GGiebelEtAl-StateOfTheArtInShortTermPrediction_ANEMOSplus_2011.pdf)

Source: Mann [2012], edited by the main author.



### 3. WIND ENERGY MARKET STATUS

Between 40.5 GW [GWEC 2012] and 41.7 GW [BTM 2012], depending on the sources, of new wind turbine capacity was installed in 2011, bringing the worldwide total installed wind capacity to 240 GW (Figure 11). This capacity can produce about 528 TWh<sup>17</sup> of electricity in an average year, or approximately 2.7 % of global electricity demand.

With almost 18 GW of new installations, China had a 42 % market share of new installations, followed by the EU with 9.6 GW (24 %), the US with 6.8 GW (16 %) and India with 3 MW (7.5 %). Non-EU European countries and Turkey added 665 MW. Of the rest of the world, Canada with 1 267 MW (3 %) and Brazil (583 MW) also surpassed the 500-MW mark.

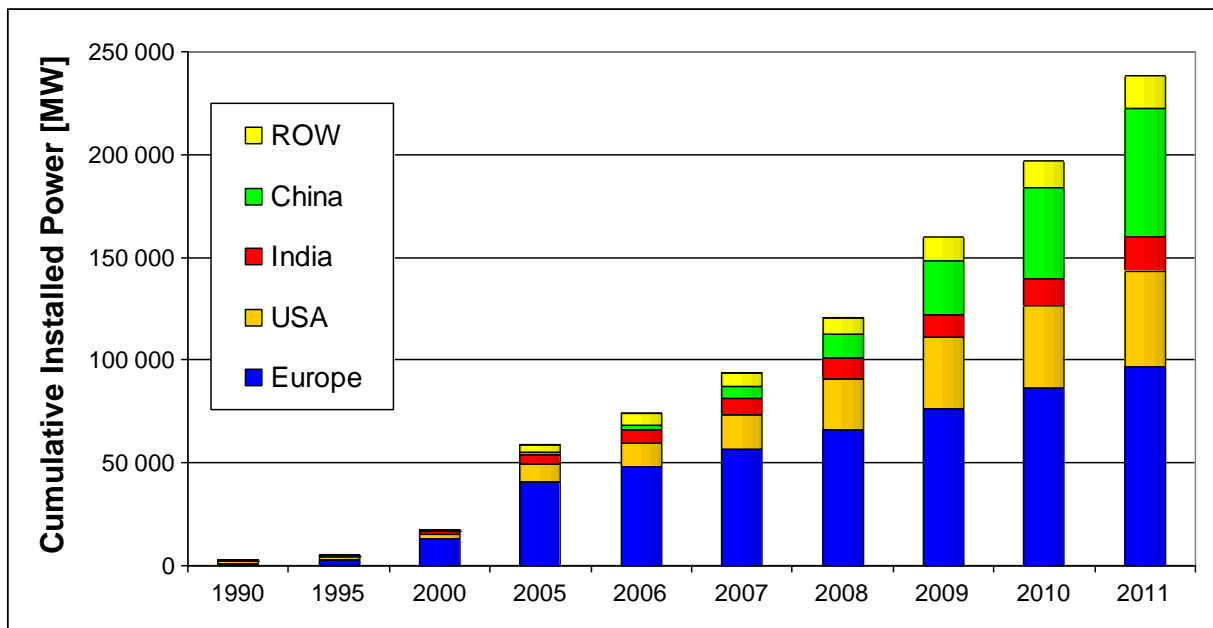

Figure 11: Cumulative worldwide installed wind power capacity from 1990 to 2011 Data Source: BTM, GWEC, WWEA, EWEA. ROW – rest of the world, “Europe” includes the EU, NO, HR, CH, TR, and UA.

The EU was still leading cumulative installed capacity with 93.9 GW at the end of 2011, whereas China increased its lead over the United States (62.4 vs. 47.1 GW, see Figure 11), although if the estimated 15 GW of non-grid-connected wind turbines in China is removed from the statistics, both countries are on a par in terms of operational capacity. India follows with 16.1 GW.

The shift in market weight towards Asia is reflected in the variations in installed capacity. After Europe led the world market in 2004 with 75 % of new installations, it took only five years for Europe, North America and Asia to reach an almost even distribution of annual market shares. Then, by 2011, Asia dominated installations with almost 52 %, whereas the North American share reached 20 %, leaving Europe with 25 %. Other continents were marginal at 3%.

In terms of percentage annual growth, in 2011, the EU’s wind capacity grew by 11.4 %, well below the global average of 20.5 %. The total EU capacity of 94 GW is 10 % of its electricity generation capacity [EWEA 2012a] and is capable of producing approximately 178 TWh<sup>18</sup> of electricity or roughly 6 % of the EU electricity consumption. EWEA reported in September 2012 that installed capacity in the EU had surpassed the 100-GW mark.

<sup>17</sup> Assuming an average capacity factor of 2200 hours or 25 %.

<sup>18</sup> Assuming a capacity factor of 1890 hours, equal to the European average for the years 2000-2009. Source: JRC based on Eurostat and industry data.

Figures for offshore wind installations vary widely depending on the source, due to the different methodologies used. Based on the date that turbines start producing electricity, 2011 saw a 25 % reduction in installed capacity from 1 009 to 765 MW<sup>19</sup>. The latter figure includes the 382 MW installed in 2011 out of the 504 MW total of the UK's Greater Gabbard wind farm which, if shifted to 2012, would leave the 2011 figure at an even more disappointing total of 383 MW worldwide. Unlike Table 6, these figures do not include intertidal wind farms.

Country	< 2001	2001	2002	2003	2004	2005	2006	2007	2008	2009	2010	2011	2012	Total
Belgium									30		165		185	379
China										63	39	8.6		112
Denmark	10	40	160	193.2						230	207			840
Finland	0.5							6	24		2			33
Germany									5	60	40	88		193
Ireland					25									25
Netherlands	19						108		120					247
Norway										2.3				2.3
Portugal												2		2
South Korea												2	3	5
Sweden	2.75	20.5						110		30			4.1	168
UK	4			60	60	90	90	100		382	556	667	357	2365
Total	36	60.5	160	253	85	90	198	216	179	767	1009	767	548	4371

Table 8: Annual installations offshore, in MW. 2012 data until September. Intertidal wind farms not included. Source: JRC database.

### 3.1. Global market status

#### 3.1.1. The European Union and beyond in Europe

In 2011 EU Member States (MS) added 9 618 MW (24 % of global), with Germany (2 086 MW), the UK (1 293 MW), and Spain (1 050 MW) as main contributors. Another four EU countries added 500 MW or more: Italy (950 MW), France (850 MW), Sweden (763 MW) and Romania (520 MW). Other European countries and Turkey added 665 MW.

The German market still represented 22 % of the EU market in 2011, presenting a year-on-year growth of 40 %, while the other traditional leader, the Spanish market, fell to third position with 11 % of the EU market (y-o-y reduction of 30 %), after the United Kingdom's 13.5 % (y-o-y +30 %). Italy with 10 % (y-o-y 0 %) and France with 8.5 % (y-o-y -24 %), complete the group of five EU countries with more than 5 GW cumulative installed capacity at the end of 2011. In other European markets, Sweden added 763 MW (+26% y-o-y), Romania 520 MW (+16% y-o-y), Poland 436 MW (+14% y-o-y). Turkey added 470 MW (- 11% y-o-y).

Over the last few years new European installations have remained at between 9 and 10 GW. Overall stability is therefore the norm in Europe, with offshore wind and new onshore markets (countries) likely to push up annual figures to around 10-12 GW per year for the next 5 to 7 years, despite a reduction in installations expected in current leading markets.

Germany (29.1 GW) and Spain (21.7 GW) lead the accumulated installations followed by three countries in the 6.5 GW range: France (6.8 GW), Italy (6.7 GW) and the UK (6.5 GW). Portugal (4 GW) and Denmark (3.9 GW) follow, then Sweden (2.9 GW) and the Netherlands (2.3 GW).

<sup>19</sup> JRC data. Intertidal wind farms not included.

Emerging wind markets are reaching a considerable cumulative capacity: Turkey with 1.8 GW, Poland (1.6 GW) and Romania (0.98 GW). The European overall situation is shown in Figure 12.

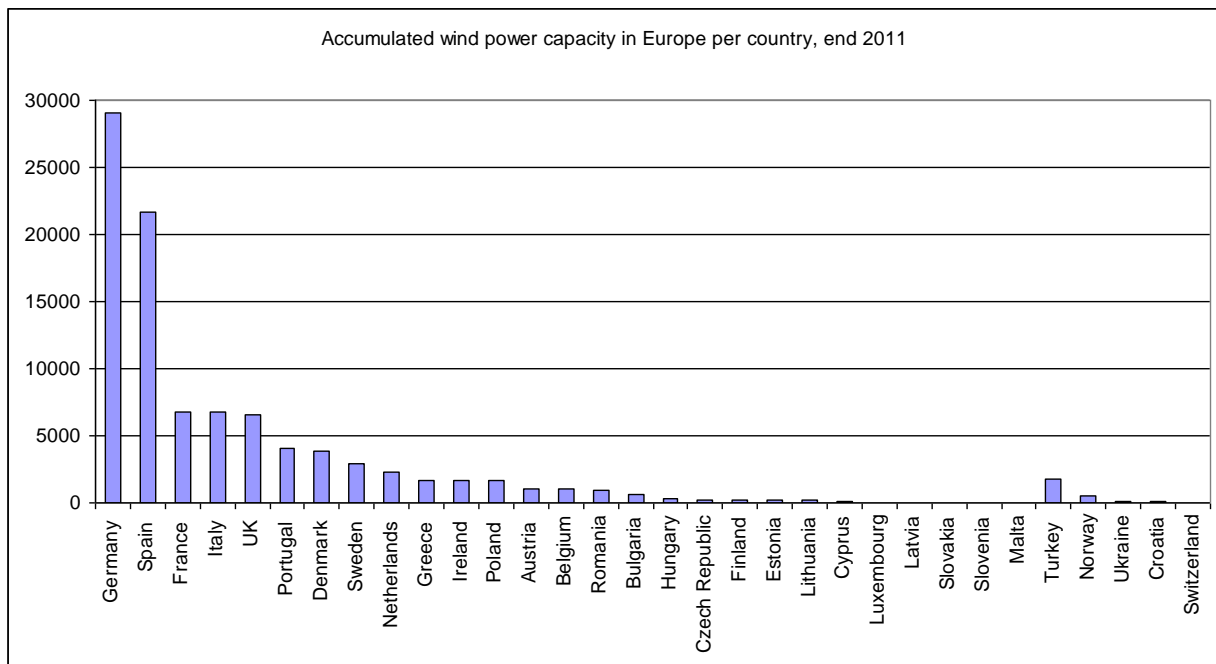

Figure 12: Accumulated wind power capacity installed in Europe per country at the end of 2011, in MW. Source: EWEA [2012]

### 3.1.2. China

For the last three years China has been the world market leader with 13.8, 18.9 and 17.6 GW respectively [CWEA, 2012a]<sup>20</sup> to reach 62.4 GW accumulated capacity at the end of 2011. Year-on-year, however, for the first time the Chinese market contracted (-7%), putting Chinese companies under pressure. Accumulated capacity grew by 39% during 2011.

In China, the connection of a wind farm to the electricity grid depends on the grid operators and not on the wind farm developers. This has caused a bottleneck in connection to the extent that traditionally around 30% of all installations remain unconnected, although this is improving.

### 3.1.3. North America

The relatively modest<sup>21</sup> growth of the US market (6.8 GW, +33% y-o-y) contrasted with the fast growth of its northern neighbour Canada (1.3 GW, +84% y-o-y). Mexico showed the poorest results with only 50 MW installed (316 MW in 2010). Canadian installed capacity reached 5.3 GW and Mexico 568 MW.

### 3.1.4. Rest of the world

The Indian market grew year-on-year from 2.1 to 3 GW (+41%) to total accumulated capacity of 16 GW. Other outstanding markets include Brazil, where wind power is the fastest-growing source of power generation, with 583 MW (+79% y-o-y) and reaching 1.5 GW, and Australia with 234 MW (+40% y-o-y), reaching 2.2 GW. The two leading African markets per installed capacity, Egypt and Morocco, experienced zero growth in 2011 and remained at 550 and 290 MW respectively.

<sup>20</sup> CWEA statistics from previous years were consulted as well.

<sup>21</sup> Compared to 2012 when a 100% growth is expected

### 3.2. Analysis and projections

Annual market projections are now a little less optimistic than two years ago, with BTM Consult expecting for 2014 installations of 52 GW, whereas two years ago that figure was estimated at 71 GW [BTM, 2012; BTM, 2010]. For the period 2013-2015, various sources estimate an annual market of between 43 and 58 GW, increasing afterwards mainly due to increased offshore installations. Due to reductions in annual growth rates, our former European 2020 projections [JRC, 2011a] have been adjusted, see section 3.6. These are now 215 GW for the EU, of which 33 GW offshore, and 715 GW globally, of which 50 GW offshore.

Factors that influence current projections include an expected reduction of the annual Chinese market to between 15 and 17 GW, stability in Europe, and a slow increase in India<sup>22</sup>, Brazil, South-Africa and other emerging markets – although not exempt from “teething” problems. In North America, the US market will likely stagnate in the absence of an extension to their main support mechanism, the Production Tax Credit (PTC), beyond the end of 2012, and, in any case, the current standoff in its extension is already deterring 2013 projects. Canada and Mexico, by contrast, are showing signs of increased growth and very positive projections, in some cases aided by know-how (e.g. developers’ know-how) escaping from the stagnating US market.

MS	Installed capacity 2020 (MW)			Watts per capita in 2020		
	Onshore	Offshore	Total	Onshore	Offshore	Total
BE	2320	2000	4320	211,85	182,63	394,5
BG	1440	0	1440	191,88	0	191,9
CZ	743	0	743	71,57	0	71,57
DK	2621	1339	3960	471,35	240,8	712,1
DE	35750	10000	45750	437,3	122,32	559,6
EE	400	250	650	298,46	186,54	485
IE	4094	555	4649	913,66	123,86	1037,5
GR	7200	300	7500	636,61	26,53	663,1
ES	35000	750	35750	758,35	16,25	774,6
FR	19000	6000	25000	292,09	92,24	384,3
IT	12000	680	12680	197,93	11,22	209,1
CY	300	0	300	357,25	0	357,2
LV	236	180	416	105,85	80,73	186,6
LT	500	0	500	154,1	0	154,1
LU	131	0	131	255,94	0	255,9
HU	750	0	750	75,11	0	75,1
MT	14,58	95	109,58	34,91	227,48	262,4
NL	6000	5178	11178	360,23	310,88	671,1
AT	2578	0	2578	306,75	0	306,7
PL	5600	500	6100	146,6	13,09	159,7
PT	6800	75	6875	639,28	7,05	646,3
RO	4000	0	4000	186,8	0	186,8
SI	106	0	106	51,7	0	51,7
SK	350	0	350	64,39	0	64,4
FI	1600	900	2500	297,66	167,43	465,1
SE	4365	182	4547	463,59	19,33	482,9
UK	14890	12990	27880	238,25	207,84	446,1
EU27	168788	41974	210762	335,85	83,52	419,4

In Europe, initial figures suggest that Germany, with 1 GW installed in the first half of 2012 year, and the UK, with 1.4 GW installed until September, will become the most significant European markets in 2012. They will continue leading the market in 2013 in particular thanks to the current higher rates of approval for onshore projects [RenewableUK, 2012] and to their offshore wind farms currently under construction.

EU Member States have drawn objectives of wind installed capacity for 2020 within the context of the EU Climate and Energy policy. Table 9 shows these projections both in installed capacity per country and in its relationship with the population.

As the Japanese society rejects nuclear power and looks to renewables to fill the gap left by the future reduction of nuclear electricity, the country could see a radical change. Japan, a traditional mid-market with 2 500 MW of total wind installed

Table 9: Projections of installed capacity and capacity per person for 2020. Source: Banja et. al [forthcoming].

<sup>22</sup> The uncertainty about support structures in India does not allow talking about a slow increase at the moment. The outlook is very uncertain for this country.

capacity, of which only 168 MW in 2011, just introduced a generous feed-in-tariff of 23 100 JPY/MWh (€227/MWh) for 20 years [METI, 2012]. This feed-in-tariff is well above any other which suggests that strong barriers force high cost of energy in Japan. Still, this tariff along with the political will behind it should boost the Japanese market for years to come.

Wind power is the fastest-growing source of power generation in Brazil. In 2011, 50 % of all newly installed wind power in Central and South America was in Brazil and at the end of 2011, there were approximately 7 GW in the pipeline as a result of an auctioning system. However, given the poor record of auctions in bringing into line capacity and the permanence in the Brazilian system of the barriers which slowed down wind projects in recent years, there is a doubt whether the country targets will be achieved [Donoso, 2012].

Perspectives are good in Africa, as in Morocco in early 2012 three projects were signed, which would more than double this capacity by 2013. In addition, an 850-MW tender was published as part of a push to reach 2 GW of wind power capacity by 2020. South Africa set up a bidding process where 1.8 GW of wind projects accepted for to be realised by 2016. As a result of the first two renewable energy project bids, projects with 1 197 MW of wind power have been awarded. The next step should add 1 470 MW of wind power [Cohen, 2012]. However, the process is experiencing problems and delays in a similar way to Brazil [Addie, 2012]. Egypt was planning to increase capacity to about 2.7 GW by 2016 and 7.2 GW by 2020, although its current political instability could jeopardise the achievement of these goals.

### 3.3. Turbine manufacturer’s market

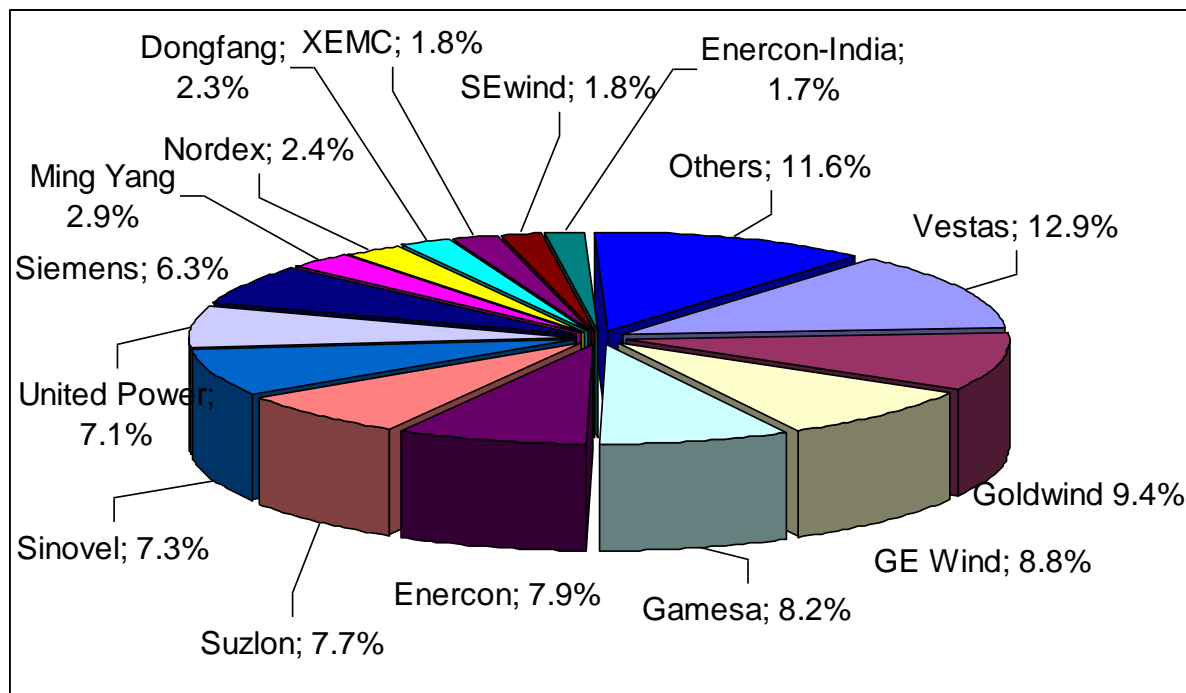

Figure 13: Market shares of manufacturers 2011 (41.7 GW of installations) [2]. Suzlon data includes its subsidiary REpower (Germany). Enercon-India does not belong to Enercon Germany. Source: BTM [2012]

Denmark’s Vestas continued topping the list of manufacturers in 2011, followed by Goldwind of China and GE Wind of the US (Figure 13). The high contribution of the Chinese market to global installations (42 %) resulted in Chinese manufacturers accounting for four of the top 10 wind turbine manufacturers (and seven of the top 15) [BTM, 2012], including Sinovel (7), Guodian United Power (8) and Ming Yang (10). This world ranking is the result of Chinese firms’ dominance of their national market (91 % of it in 2011) [CWEA, 2012a] and Chinese firms

commissioned less than 100 MW outside China in 2011 [JRC data]. This figure is less than 0.6 % of the total 16 000 MW installed by Chinese firms. By contrast, foreign firms installed 1 626 MW in China, albeit with a reduction of 19 % over the 2 000 MW installed in 2010.<sup>23</sup>

In 2011, Vestas with 12.9 % of the market was clearly ahead of a group of eight manufacturers with very similar market share, mostly between 7 and 9 % (Goldwind, GE, Gamesa, Enercon, Suzlon, Sinovel and United Power). There is then a gap as the next manufacturer, Ming Yang, captured only a 2.9 % of the market.

Historically the market has tended towards more atomisation, with more small suppliers gaining a market share according to BTM [2010, 2011, 2012 and similar reports from previous years]. Table 10 shows the top-10 manufacturer position from 2005 to 2011, and the shares of the top-five, top-10 and EU manufacturers in the top-10.

This reduction of the share of top tier-1 manufacturers is even more clear in the case of the market leader, Vestas, which has seen its share reduced from 27% in 2005 to 13% in 2011. Note that a significant cause of the evolution of market share is the growth of the Chinese market since 2008, its much larger size regarding any other market, and the prominence that Chinese OEMs have had in their market.

Position	2011	2010	2009	2008	2007	2006	2005
1	Vestas	Vestas	Vestas	Vestas	Vestas	Vestas	Vestas
2	Goldwind	Sinovel	GE	GE	GE	Gamesa	GE
3	GE	GE	Sinovel	Gamesa	Gamesa	GE	Enercon
4	Gamesa	Goldwind	Enercon	Enercon	Enercon	Enercon	Gamesa
5	Enercon	Enercon	Goldwind	Suzlon	Suzlon	Suzlon	Suzlon
6	Suzlon	Suzlon	Gamesa	Siemens	Siemens	Siemens	Siemens
7	Sinovel	Dongfang	Dongfang	Sinovel	Acciona	Nordex	REpower
8	Guodian	Gamesa	Suzlon	Acciona	Goldwind	REpower	Ecotècnia
9	Siemens	Siemens	Siemens	Goldwind	Nordex	Acciona	Nordex
10	Ming Yang	Guodian	REpower	Nordex	Sinovel	Goldwind	Mitsubishi
Top-5	47.2%	52.2%	49.8%	62.3%	67.9%	75.8%	76.4%
Top-10	78.5%	82.5%	78.7%	84.2%	87.2%	93.8%	93.2%
EU	35.3%	34.5%	37.0%	51.3%	57.5%	70.0%	66.2%
Market	41.7 GW	39.4 GW	38.1 GW	28.2 GW	19.8 GW	15 GW	11.5 GW

Table 10: Market share of the top-10 manufacturers 2005 – 2011. Source: JRC analysis based on BTM [2010, 2011, 2012] and on similar reports from previous years. Orange background reflects EU companies, and the share of EU companies in the top-10 is shown in the “EU” row. Global market figures (in GW) from BTM (see above)

The wind turbine-manufacturing sector currently has production overcapacity, particularly in China, as markets did not grow as fast as manufacturers expected. Players in China, the largest world market, are under additional pressure as its size is expected to decrease in the short term because of the new legislation put in place by the Chinese government to improve management of installations and grid connection. Taken together, these factors should result in sector consolidation, along with an increase in Chinese companies' exports that will further result in price pressure for European manufacturers both at home and abroad. This pressure is starting to present results in the current year (2012): more than 400 MW of Chinese turbines have been installed or are being installed in at least nine countries outside China (US, CL, EC, ET, PK, AU, BG, SE and IE)

<sup>23</sup> Figures for the Chinese market correspond to installed turbines whereas those elsewhere correspond to fully commissioned and grid-connected turbines.

Chinese manufacturers will therefore start seriously grabbing a part of the market outside their home country, starting with the technologies that are more bankable<sup>24</sup>. Nowadays, these are mostly turbines with permanent-magnet generators and a full converter, based on European designs (e.g. Goldwind-Vensys, XEMC-Darwind). This trend will be aided by the fact that non-Chinese turbine manufacturers increasingly source from the Chinese supply chain, and thus companies in this supply chain are reaching foreign levels of quality.

The entry into Western markets of both bankable and not-so-bankable Chinese turbines is being done (a) by manufacturers becoming developers of wind farms where they use their own machines; (b) with the help of Chinese banks providing the finance for projects. Countries where this is happening include the US, India, Romania, Pakistan and some in South America.

### 3.4. Repowering old wind farms

A market which starts to open in a significant way is the one of repowering old wind farms with new machines. In particular for the pioneering countries (Germany, Denmark, Spain or the UK), wind farms built in the 80s and 90s have already recovered capital investment and are faced with higher O&M costs, low yields and more demanding grid codes. The solution is to replace the old machines with a lower number of new turbines of much higher rated power and better efficiency. Some countries (e.g. Germany with 5€/MWh, Denmark) are encouraging this trend by allocating a slightly higher feed-in-tariff to repowered wind farms.

A rule of thumb is that repowering an old wind farm requires half the number of turbines resulting in double the installed capacity and tripled electricity generation [BWE, 2012].

Number of wind turbines and total capacity	2006	2007	2008	2009	2010	2011	2012 H1	Cumulated
Decommissioned turbines	79	108	26	76	140	170	15	994
Replacement turbines	55	45	18	55	90	95	10	551
Decommissioned MW	26.19	41.29	9.74	36.7	55.7	123	8.7	460
Replacement MW	136.4	102.9	23.94	136.2	183.4	238	26	1190

Table 11: repowering activity in Germany 2006 - 2011. Source: BWE annual reports

By the end of 2000 13 GW of wind turbines were installed in the EU of which an estimated 9 GW correspond to turbines with a rated power of 1 MW or lower. These pioneering installations are located in sites often gifted with better wind resources than what is available in today's greenfield projects. There is, therefore a large potential for repowering.

### 3.5. Industrial strategies

Increasing international competition imposes production reorganisation of the European wind technology manufacturers with one objective: reducing costs. However, manufacturers may focus on two different cost concepts: levelised cost of energy (LCoE) or capital expense (CapEx), the latter having more limited range and sometimes causing a higher LCoE through higher operation and maintenance (O&M) costs. Searching for new business opportunities and energy solutions, turbine manufacturers are developing and analysing new technologies and markets, diversifying their activities.

<sup>24</sup> For example MingYang's partnership with Reliance Group of India "to co-develop up to 2.5 GW of renewable energy projects in India and South Asia", or Goldwind's partnership with Mainstream of the UK to develop projects in South America and elsewhere.

Following analysis by Porter [1980] industrial strategies in the wind power sector can be grouped in the following areas: product and service diversification, cost reductions and market segmentation.

### **A. Diversification of wind products, wind services and business portfolio**

Wind technology manufacturers are enhancing their product variety, enlarging their business solutions and increasing their business portfolio.

Product variety. Wind technology manufacturers customise solutions for new markets, enhance product variety and adapt technologies to different local context, and improve efficiency of existing manufacturing turbines. Consequently, companies offer onshore and offshore solutions (e.g. Vestas/Siemens/REpower/Sinovel), only onshore solutions (e.g. Enercon, Suzlon), only offshore solutions (e.g. Areva) and low wind speed solutions (Vestas, Enercon, Vergnet, Sinovel, Suzlon).

Service diversification. Turbine manufacturers are operating in different business areas: from suppliers-only to wind farm developers and O&M service providers. Vestas operates with three types of turbine contracts: “supply-only”, “supply-and-installation” and “turnkey”. For the supply-and-installation and turnkey orders, Vestas is responsible for installing and connecting the turbines to the power grid and for the entire project including all engineering works<sup>25</sup>. In China, Goldwind is mainly engaged in the same business segments as other European turbine manufacturers: manufacturing and sales of wind turbines, wind power services and wind farm development<sup>26</sup>. By contrast, Sinovel's main business is in wind turbine production and, during the reporting period, wind turbine sales accounted for 99.9% of its revenue.

It is interesting to note that, in addition to OEMs and independent service providers, a further group (wind developers) is entering the O&M service business [EDF, 2012]. This will squeeze still more the margins of this market sub segment and, as a consequence of these additional actors in the business, O&M prices will fall further thus putting more pressure on turbine OEMs.

The diversification of the business portfolio may trigger developments in new areas of renewable energy, such as energy efficiency and grid integration. If we look into EPO patent applications,<sup>27</sup> we notice in recent years an intensified activity of these companies to perform research activities in grid and renewables-related topics (e.g. Gamesa to hydropower, PV and others<sup>28</sup>).

### **B. Cost reduction through high output, level of direct and indirect costs, supply/procurement chain to ensure lower cost.**

Strategic alliances enable the development of large production capacity which in turn allows for economies of scale and potentially the reduction of risks. In addition, business models such as joint ventures and licensing allow cost reductions and market expansion.

<sup>25</sup> Revenue in the service business amounted to EUR 623m in 2010, an increase of 24 %relative to 2009 (504 million), already increased of 27% with respect to 2007 levels.

<sup>26</sup> Investment, development and sales

<sup>27</sup> EPO classification allows to separate the patents related to grid topics

<sup>28</sup> “Gamesa impulsa su diversificación tecnológica e industrial en los sectores hidroeléctrico, fotovoltaico, calidad de energía, tracción eléctrica y propulsión marina.”. Gamesa press release 4th October 2012



Strategic alliances facilitating high volume of output. The increased share of wind power in the total energy supply and ever growing globalisation of activities had as consequence that larger customers and utility companies account for a growing share of demand of wind turbines. This development imposes a reorganisation of wind turbine manufacturers with a growing tendency to cover the needs of large customers. The following companies exemplify the extent to which partnership agreements vary from short-term one-off projects to long term and larger commitments (such as framework agreements):

- Vestas Wind Systems (DK) cooperates with large utilities in international operations. Vestas was organized to serve also small, local customers, but recently focuses on increasing the share of revenues coming from large customers. In 2011, the average order was for 22 MW, the biggest one being 267 MW (from E.ON Climate & Renewables GmbH)<sup>29</sup>. In terms of revenue, utility companies accounted for 43 % of revenue. The trend towards larger customers is confirmed by a large share of orders coming from large customers: the ten largest customers accounted for 21 per cent of the orders intake in 2011. Vestas signed a framework agreement with EDF Energies Nouvelles for up to 2 000 MW.
- Siemens Wind Power (DK/DE) promotes large framework contracts. In 2009 Siemens signed a large framework agreement with developer DONG Energy (DK) of “up to 500 wind turbines”<sup>30</sup> and, in 2012, a new agreement for 600 turbines of the new model SWT-6.0-154 which with DONG becomes the launch client<sup>31</sup>. Siemens also signed a contract with E.ON, for 500 2.3MW onshore turbines, 1150 MW in total, for installation in US (600 MW) and Europe (550 MW).
- REpower in 2009 signed a framework agreement with RWE Innogy for the supply of up to 250 turbines of the 5M/6M class for offshore wind farms<sup>32</sup>, up to 1500 MW.
- Gamesa (ES) signed a memorandum of understanding with China’s Longyuan (third largest world wind developer) “to jointly develop wind projects in international markets outside of China”. Gamesa also focuses on large utilities (Iberdrola) that need to expand in new markets and on local developers or industrial groups.
- Also Chinese companies target large customers: Sinovel shows an increased trend for larger customers. In 2010, total sales of the top five customers in the company accounted for 26% of the company's main business income.

Lower direct and indirect costs. In order to achieve cost leadership, the reduction of direct and indirect costs is combined with the re-localisation of production facilities. For example, the reduction of transport costs was one of the justifications used by Vestas in its globalisation strategy.

Another way of reduction of expenditures is achieved through licensing from an established manufacturer (Flessak/DeWind, Goldwind/REpower) or a design company (e.g. United Power/Aerodyn); purchasing a smaller OEM with solid R&D (e.g. Goldwind/Vensys); or agreements with R&D institutions (Ming Yang/Riso-DTU). However, large technology manufactures (e.g. Vestas, Enercon, Siemens, GE, Gamesa, Nordex) continue to perform in-house research and development .

<sup>29</sup> In 2010, Vestas secured two major contracts in Australia: 206 MW in Western Australia, as well as a contract for the largest wind farm in the Southern Hemisphere, with 420 MW of generation capacity coming from 140 V112-3.0 MW wind turbines

<sup>30</sup> [http://www.siemens.com/press/en/pressrelease/?press=/en/pressrelease/2009/renewable\\_energy/erc200903029.htm](http://www.siemens.com/press/en/pressrelease/?press=/en/pressrelease/2009/renewable_energy/erc200903029.htm)

<sup>31</sup> <http://www.siemens.com/press/en/pressrelease/?press=/en/pressrelease/2012/energy/wind-power/ewp201207059.htm>

<sup>32</sup> <http://www.rwe.com/web/cms/en/86182/rwe-innogy/news-press/press/?pmid=4003016>

Supply chain control. Most European companies are manufacturing in-house wind turbine components (e.g. Vestas, Enercon, Gamesa). In-house manufacture presumably ensures a better quality control, but other sources suggest that specialised component manufacturers can make their product to a higher quality. In the past, REpower outsourced the manufacture of wind turbine components, but has recently moved towards an integrated manufacture; in 2012 it has entirely acquired the wind turbine blade manufacturer PowerBlades GmbH, which will in particular allow the production of rotor blades for the offshore sector. Siemens manufactures its own blades, whereas Nordex, which started selling its new N117 machine with blades from other manufacturers, is now setting up its own blade production plant.

Contrarily, in the United States 67 % of the components of wind turbines are manufactured domestically [Wiser and Bolinger, 2012]. Among the components most imported by American companies are: the heavy hubs for a 1.5 MW turbine (General Electric), 18 tonnes tower supports, drive shafts, nacelle parts and hubs (Clipper Wind).

### ***C. Market segmentation occurs through globalisation***

The proliferation of new wind markets leads to technological improvements, new business solutions, new products and production reorganisation of European companies in order to serve the customers in these regions.

Some companies remain national (Regen/IN), others go global (most non-Chinese top-15 OEMs). According to principles such as “in the region for the region” (Vestas) or “thinking globally and acting locally” (Gamesa), European companies invest in a regional structure are able to increase their competitiveness and to reduce the environmental and climate costs. During the period 2005-2010 Vestas invested € 2.3 billion especially in its two largest markets, the USA and China: Vestas commissioned a new foundry in Xuzhou (China), a 850-kW turbine factory in Hohhot (China) (closed in 2012), a tower factory in Pueblo (Colorado, USA), and a nacelle assembly factory and a blade factory in Brighton (Colorado, USA). Also, significant amounts of capital expenditure (EUR 579 million) at the energy sectors (including wind) allowed Siemens to seek expansion of the capacities in strategic growth markets and to secure competitiveness in technology-driven growth for wind power markets.

Alternative ways to tackle new markets is through establishment of subsidiaries, joint ventures (JV) and licensing to a local player. A JV strategy is sometimes forced by national laws e.g. of local ownership (CN) or by the logic of better access to the local culture (IN). The market expansion towards India is pursued by Gamesa also through its new joint venture Windar. However, an example of failure in market expansion was Enercon in India, where the European company lost its Indian subsidiary to the Indian local partner in 2011, amid several still unresolved court cases.

## **3.6. Deployment scenarios**

The European Wind Industry Energy Association has defined targets of 230 GW installed in Europe by 2020, of which 40 GW offshore and 400 GW installed by 2030, of which 150 GW offshore.

The construction of deployment scenarios is supported on an assessment of actors that have a say in future deployment as much as in the technology, global and sectoral economic situation. The following points formed the basis of our assessment:

- Wind energy is a local resource widely distributed. Its use makes countries independent from fuel imports from unstable countries, improves security of supply and does not have negative environmental impacts.
- Human-induced climate change is a reality asserted by scientific effort. The society generally understands the dangers of climate change and supports doing something about it. Political objectives generally include short-, medium- and long-term reductions of fossil fuel use.
- Current policies translate this societal need into plans and support for renewable energies including wind. Politicians have broadly stated their will to support renewables as necessary to tackle climate change.
- Wind energy technology continues to improve its reach and to reduce its cost. This is resulting in the opening of new markets (Brazil, South Africa...) and more will be created as costs reduce further. However, offshore wind is taking longer to reduce its cost significantly.
- Some bottlenecks need to be considered, e.g. installation of export cables for offshore wind farms.
- The Fukushima nuclear plant disaster, which has exposed the weaknesses of nuclear installations to certain natural phenomena, has triggered in some countries an energy policy switch towards renewables. Germany and Japan have made strong policy statements to increase their support for renewables and, although not with the same level of commitment, other countries follow track.

In Europe, the 2020 projections based on the National Renewable Energy Action Plans (NREAPS) suggest that offshore installations will increase from 2.6 to 44 GW (a 15-fold increase) significantly more than onshore (from 82 to 169 GW, a 2-fold increase) [Banja et. al, forthcoming]. The track record of more accurate predictions by EWEA suggests that their projections are more likely to be achieved.

Therefore we suggest the following deployment scenarios as likely for the European Union and the whole world, in gigawatts (GW):

	EU			World		
	Total	Onshore	Offshore	Total	Onshore	Offshore
Cumulative capacity 2011	94	90	3.7	240	236.1	3.9
Installed 2012-2015	51	43.7	7.3	175	162.9	12.2
Annual installation rate	12.8	10.9	1.8	43.8	40.7	3
Installations 2016-2020	70	48	22	300	266	34
Annual installation rate	14	9.6	4.4	60	53.2	6.8
Cumulative by 2020	215	182	33	715	665	50
Installations 2021-2030	135	50	85	750	550	200
Annual installation rate	13.5	5	8.5	75	55	20
Cumulative by 2030	350	232	118	1465	1215	250
Installations 2031-2050	200	40	160	1075	725	350
Annual installation rate	10	2	8	54	36	18
Cumulative by 2050	550	272	278	2540	1940	600

Table 12: Estimated installed capacity in GW, 2011 - 2050. Sources GWEC [2012] (for 2011 data) and JRC analysis

The European share of world cumulative capacity will continue to shrink from the current 40 % to 30 %, 24 % by 2030 and 22 % by 2050. In 2006 this share was 69 %.

We expect the onshore market to dominate in Europe until 2020 and sometime before 2030 to pass the baton to the offshore sector. Repowering (see section 3.4) will play a significant role, in terms of annual installations, possibly from 2015 in DE, DK, NL and ES, and will be followed by other countries. From 2031 onwards new installed power is likely to correspond only to repowering of current wind farms.

In the rest of the world onshore installations will probably dominate all the way to 2050, despite the cost reductions that will materialise much earlier.

Both in Europe sometime after 2030 and in the world after 2050, the pace of installations will slow down to the level of replacement of obsolete equipment. New technologies will still allow cumulative capacity to increase regarding the decommissioned capacity (repowering).

## 4. ECONOMIC IMPACTS OF WIND ENERGY

The cost of wind energy depends on the cost of raw materials; technology fundamentals; supply bottlenecks (e.g. limited competition in offshore cable supply); market supply/demand balance; administrative barriers (permit process etc., including those caused by NIMBYism); the mode and level of remunerating wind electricity, e.g. feed-in tariffs (FiT); and on risks and uncertainties impacting on the investors and lenders.

The calculation of the cost of wind is carried out through the levelised cost of energy (LCoE), a standard for all energy-generating technology. In the case of wind, “energy” is equivalent to “electricity” as the technology does not generate thermal energy.

### 4.1. Economic indicators

Defining the LCoE from wind is based on three main economic indicators and one physical one: capital costs (CapEx, also called total installed costs); operations and maintenance costs (OpEx); interest or discount rates; and annual energy production (AEP). The formula which links them is:

$$LCoE = \frac{L.I. + DO \& M}{E} \quad [\text{SETIS, 2011}]$$

Where:

- LCoE (€/MWh): The levelised cost of generating electricity
- L.I. (€/y): Levelised investment, result of applying a capital recovery factor (CRF) to the project capital cost.
- DO&M (€/y): Annualised (discounted) operation and maintenance cost
- E (MWh/y): Annualised energy production

The CRF concept breaks down the initial capital cost in equal annual payments using a discount rate and the lifetime of the technology. The levelisation is performed using the following formula:

$$CRF = \frac{d}{(1 - (1 + d)^{-N})}$$

Where:

- d (%) is the discount or interest rate
- N is the expected lifetime of the project in years

A systems approach to techno-economic assessment requires that the elements under assessment are consistent and that the same elements are included in the system across the countries or technology assessed. For example, for some sources of data, CapEx includes the financial cost of the construction phase whereas for others this is not the case.

The elements that make up LCoE contain country-specific differences, and this hinders an assessment based on LCoE. One way to a better assessment is to focus on wind turbine cost (or price) in wind projects. The JRC analysis of data from IEAWind [2012] shows that the ratio of maximum to average wind turbine costs across a selection of countries in 2011 is 1.63 compared with 1.76 for CapEx. This suggests higher consistency in the case of wind turbine costs.

However, using turbine costs as an indicator for wind techno-economic assessment has also limitations. There is evidence that factors outside the control of the wind sector and others

completely unrelated to the technology have caused strong cost variations in the past. These are exchange rates, market supply/demand unbalance, overcapacity of production and increases in the price of raw materials (which can be exacerbated throughout the supply chain).

Country	Turbine costs (EUR/kW*)		Total installed costs (EUR/kW*)		Installed capacity MW
	Min	Max or avrg	Min	Max or avrg	
Australia	870	1 570	1 300	2 670	234
Austria	1 400	1 800	1 600	1 900	73
China**		468	861	984	17 631
Ireland		1 000	1 600	2 100	239
Italy		1 200		1 750	950
Japan		1 980		2 970	168
Mexico	1 100	1 200		1 500	50
Portugal	900	1 000		1 400	377
Spain		820	1 000	1 400	1 050
Sweden		1 400		1 600	763
Switzerland		1 450		2 100	3
United Kingdom		<b>1 018</b>		<b>1 580</b>	1 293
United States	818	1 004		1 562	6 810

Table 13: Estimated average turbine cost and total project cost for 2011 in selected countries. Source: IEAWind [2012]<sup>33</sup> for costs\*\*\* and GWEC [2012] for installed capacity.

\* Exchange rate 1 EUR = 1.294 USD

\*\* China turbine figures may include different components than those of other countries.

\*\* Onshore UK prices not from IEAWind but from Mott MacDonald [2011], exchange rate 1.17 EUR/GBP

The analysis of a selection of the onshore country data (turbine and CapEx cost) provided to IEAWind [2012], along with cost data for the UK from [MML, 2011] and capacity data from [GWEC, 2012] suggests that the average “Western” wind project CapEx was **1580 €/kW**, and the average turbine cost was **998 €/kW (63.2 % of project cost)**. This selection covers the equivalent to 30% of installed capacity in 2011 -Chinese and Indian data (the lowest cost of all) excluded - but it is uncertain whether it covers plants actually installed in 2011 or for which the turbine purchasing decision was taken in 2011.

## 4.2. Economic aspects

### 4.2.1. Turbine costs

Up to 2004 turbine prices declined influenced by technology learning and the increasing volumes of production, then started to increase. From late 2007 supply/demand imbalances and the increase of raw material and component prices pushed up onshore turbine prices to around €1 150/kW in 2009. Then the reduction in raw materials costs caused by the financial crisis, plus manufacturing overcapacity and increasing competition pushed down turbine prices drastically to around €950/kW. From then onwards priced stagnated to mid-2011, when a new market segment started to rise: low-wind sites. New turbines, designed specifically for low-wind sites, feature taller towers and larger rotors which allows for higher prices. As towers and blades make up 35 – 45% of the cost of a turbine, prices started to diverge for new and old technology (see Figure 15).

<sup>33</sup> CA, CN, DE, DK, FI, GR, KR, NL, and NO, were excluded from this assessment because of methodological differences or lack of complete data. CN data, however, was included in the table for illustration purposes.

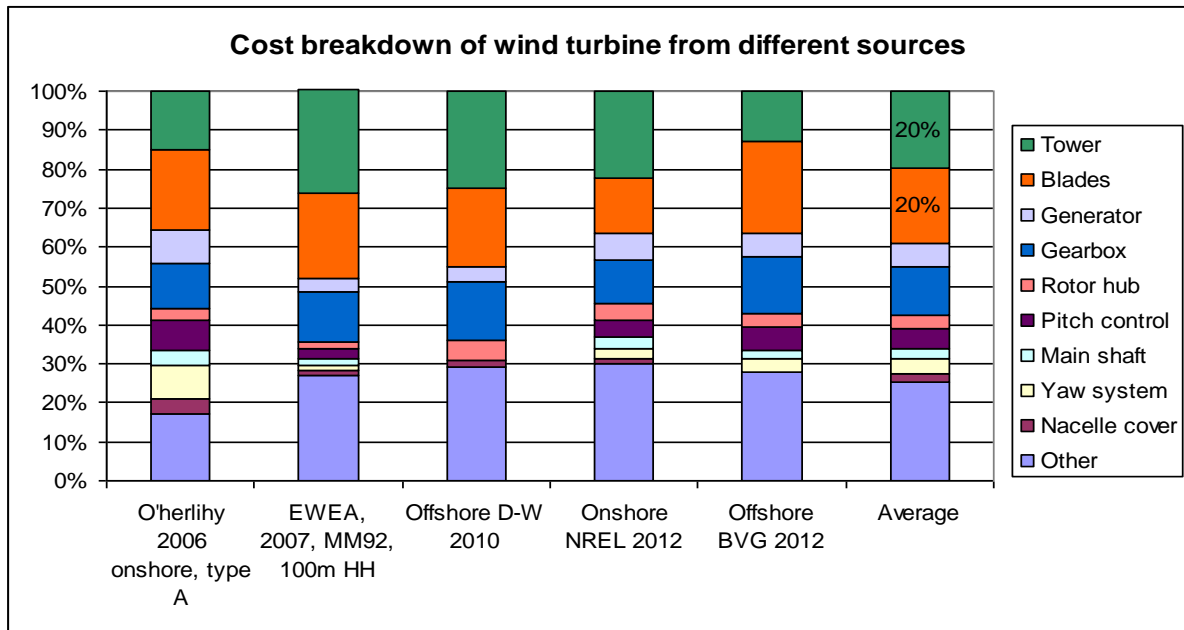

Figure 14: Cost breakdown of wind turbines, in percentage, for different authors: O'Herlihy [2006], EWEA [2007], Douglass-Westwood [2010], NREL [2012], and BVG [2012].

Figure 14 shows the cost breakdown of wind turbines into components, from different sources. These are consistent in that towers and blades are the most expensive elements of a wind turbine. The lower cost of the tower in BVG [2012] is due to its lower height, calculated at half the rotor size plus 22m or around 80m. The opposite is seen in EWEA [2007], a turbine with a large rotor for the time (92m, 2007) and a tall tower (100m).

Figure 15 shows the evolution of average world turbine prices excluding Chinese installations, from a different source [BNEF, 2012a]. The graph is based on the turbine delivery date according to the purchasing contracts. Due to the 1 – 2 year gap between signature of the contract and the installation of the turbines information, data for up to the second half of 2013 is available. The graph reflects the difference in prices per (new, old) technology as described above.

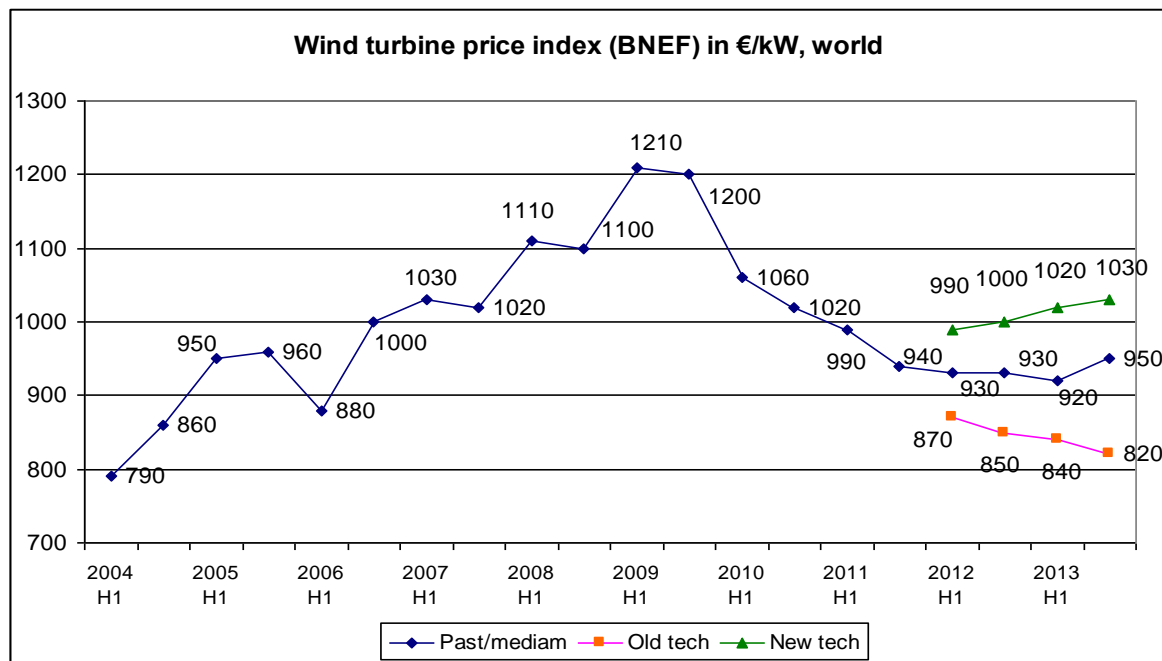

Figure 15: Evolution of wind turbine prices based on the year of delivery. Source BNEF [2012a]

Average turbine prices are increasing reflecting the increased share of new technology, and this same technology split is likely to be a key cause of price differentiation between markets: in Europe Spain, Italy, the UK and France markets show the lowest prices, and the Scandinavian markets the highest [BNEF, 2012a]. Beyond Europe, the US at €883/kW (at 1 EUR = 1.29 USD) and China at €484/kW (at 1 EUR = 8.1 CNY) showed lower prices. Price quotes include transport to the site but not installation. In China some other equipment is not included<sup>34</sup>.

The high price of turbines did not turn into high profits for their manufacturers. European manufacturers published 2011 EBIT in the range of 0 to 5 % and in 2012, unlike the previous years, Chinese manufacturers are also suffering this effect [BNEF, 2012b].

Offshore turbine prices are in the range of €1350 - €1500/kW [BVG, 2012; MML, 2011].

#### 4.2.2. Capital expenditure (CapEx)

The cost of the wind turbine is the main cost of onshore wind projects, but its share has been slowly reducing from around 70% to around 63% in a few years. Offshore, the share of turbine costs in total CapEx is lower at 30 – 40%.

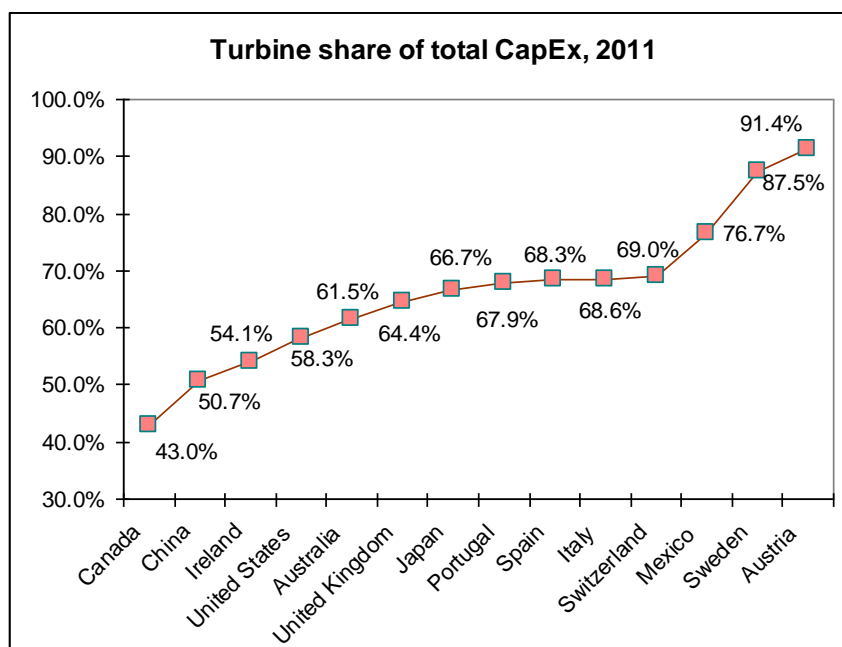

Figure 16: Turbine share of CapEx, 2011 except Canada (2012). Source: GL-GH [2012] for Canada, MML [2012] for the UK, and IEAWind [2012] for the rest.

Figure 16, plotting mostly information from Table 13, shows the different share of the cost of the turbine in the total CapEx for selected countries. The low figure for Canada is most likely due to long distances affecting turbine transport and grid extension costs. Chinese data has slightly different components (footnote <sup>34</sup>). The figures for Austria and Sweden seems unusually high, but the source could not be contacted for clarification.

European average CapEx for onshore projects showed a reduction to €1 000/kW in 2003/4, and then climbed to reach its peak in 2008, then down to around €1 250/kW in 2010 [EU, 2011]. In the USA, the DoE suggests a CapEx level around \$2 190/kW (€1 651/kW) in 2010 reducing to \$2 100/kW (€1 510/kW) in 2011 [Wiser and Bolinger, 2012]. First indications about CapEx in 2012 suggest a further, significant reduction to about \$1 755/kW (€1 370/kW @ 1,282 USD/EUR exchange rate).

The estimation of general CapEx for offshore wind farms is hindered because each project is site specific and very different to all the others, and the out-turn costs will vary hugely depending on depths, geology, distances from ports, tidal patterns, weather, manufacturing sites, availability of vessels etc. [Balmer, 2012]. On a first approximation, however, offshore CapEx showed strong

<sup>34</sup> Turbine prices quoted in China do not include foundations, civil works, installation, farm substation, cabling, transformers (in most cases they are not included, often they are placed outside of the wind turbine), control and monitoring of installation. Transport to the site is included in the turbine price [Chen, 2012]



price increases from €2 200/kW in 2007 to €3 000 – 4 200/kW in 2011 with the upper end covered by farther offshore, deep-water wind farms [JRC, 2012a]. MML [2011] suggests that raw material costs are not that significant but instead prices of offshore wind included a market premium in the order of 20 %. This is notably higher than for onshore wind due to significant risks related to both construction and operation.

Source	€/kW	Data yr	Scope
EWI (JRC)	1 250	2010	Onshore, EU average
Ecotricity	1 150	2012	Onshore. Declaration to the CCC (UK) of the cost for a 20.7-MW project, inc. grid connection
Mott MacDonald	1 556	2011	Onshore, UK
IEAWind	1 626	2011	Weighted avrg IEAWind except CN: AU, AT, CA, DK, DE, IE, IT, JP, MX, NL, PT, ES, SE, CH, UK, US.
NREL	1 548	2010	US, large DB, very reliable data but only US
GL-GH	2 574	2012	BC (CA), onshore, remote region
EWI (JRC)	3 500	2010	Offshore, EU average
BVG associates	2 854	2012	Offshore, UK, modelled for the Crown Estate, min CapEx
Cpower	3 800	2011	Offshore, Thornton Bank II & III project, BE
Navigant Consulting	4 705	2012	Offshore, US, modelled for a DoE working group

Table 14: Different CapEx from different reliable sources, periods 2010-2012

It is important to note the variability of CapEx figures between countries and over time. In addition to Table 13, which represents somehow an official view of the countries contributing to the international joint effort IEAWind, there is the vision of industry researchers. Table 14 shows the range of variation in reported CapEx from some very reliable sources.

Country	€/kW	MW	Country	€/kW	MW	Country	€/kW	MW
India	1 058	1 422	Dominican R.	1 571	8	Maldives	1 862	100
China	1 168	10 869	Bulgaria	1 574	<b>460</b>	Sweden	1 872	39
Turkey	1 178	178	Mexico	1 623	<b>374</b>	Canada	1 915	852
Czech Republic	1 226	<b>75</b>	Poland	1 643	173	Italy	2 023	244
South Africa	1 293	72	Portugal	1 643	267	Jamaica	2 048	18
Belgium	1 358	12	Japan	1 663	47	Honduras	2 206	102
New Zealand	1 376	108	United States	1 682	2 712	Costa Rica	2 221	13
Ukraine	1 385	<b>475</b>	Ireland	1 694	46	Norway	2 267	85
Senegal	1 428	125	Romania	1 697	16	Cyprus	2 324	82
France	1 494	135	Lithuania	1 710	6	Chile	2 329	30
Spain	1 496	128	Australia	1 732	<b>833</b>	Cape Verde	2 353	26
Brazil	1 530	91	S. Korea	1 788	25	Kenya	3 538	7
Philippines	1 552	40	Switzerland	1 799	<b>7</b>	Germany off-	3 975	45
Germany on-	1 570	48	UK	1 843	610	World wei. avrg	1 389	<b>21 005</b>

Table 15: Average country CapEx for projects implemented in 2011. Source: JRC calculations based on data from Bloomberg New Energy Finance

Table 15 shows the country average CapEx from a commercial database containing 389 projects implemented in 2011. The figures, converted to EUR/kW, correspond to projects for the stated installed capacity (in MW), for which a comparison with GWEC [2012] would show the ratio to total country installed capacity covered. Data in bold/italics suggest methodological differences with GWEC [2012] or data inconsistencies.

Irrespective of data inconsistencies, the table shows one definite conclusion: there are huge differences between countries. In order to find out more about reducing the cost of energy these differences should be analysed and a model built which should show the impact in CoE of acting on the different factors creating the CapEx, whether legislative, materials, design, etc. (see subsection 4.2.9 below)

Note that, in general, increasing redundancy in a modular context increases CapEx but ensures a more robust machine and therefore less downtime and lower OpEx. This affects particularly the electrical components, and it is offshore that it is more important.

#### 4.2.3. Operational expenditure (OpEx) - general

Operational expenditure can be divided into expenses linked to maintenance (predictive, preventive and corrective), and all the other expenses necessary to operate the wind turbine or farm: insurance, land rental, cost of exporting electricity, cost of trading electricity in wholesale markets, local taxes, national taxes, management and administration, etc. We call the first group O&M and the latter group “*other operating costs*”.

Onshore O&M costs were estimated at €21/MWh (or €47/kW/yr at a 25 % capacity factor) in 2010, but there is evidence of a significant reduction to 8 – 10 €/MWh [JRC, 2012a] over the last five years because of several drivers:

- Increased competition. OEMs are entering this market and making aggressive offers.
- Economies of scale. Increasingly utilities have become large developers and owners of wind farms and this gives them higher purchasing power when negotiating with O&M suppliers.
- Improvements in wind turbine reliability. Sometime during the last decade the sector, i.e. different manufacturers at different points in time, realised the importance of improving the reliability of turbines. These changes are showing up now in more reliable machines which require less maintenance and provide higher availability.

Operational expenditure is mostly constituted of fixed costs, with some of them being variable:

- 1) Fixed O&M costs: staff costs, turbine scheduled O&M, balance of plant (BoP) maintenance, some consumables.
- 2) Variable O&M costs: unscheduled O&M, repairs, some consumables.
- 3) Other fixed operating costs: electricity connection (fix part), insurance, project administration management fees, other general and administration costs.
- 4) Other variable operating costs: electricity connection (energy part), imported electricity, wind integration (mostly balancing) charges, property tax/business rates.

Land leases or royalties may take the form of a fix annual or a variable fee.

The failure of a wind turbine results in an unwanted economic by-product, the lack of income due to downtime while waiting for repair. This downtime can be very long where a large component is involved, e.g. the gearbox, a blade or the main shaft but also small components such as the power electronics of the electrical system may cause downtime if the turbine cannot be re-started remotely.

#### 4.2.4. Operational expenditure (OpEx) - offshore

Therefore, two main negative economic impacts of the operation of a wind turbine are the O&M costs and the lack of income due to downtime. Figure 17 shows the breakdown of these two

costs for a wind turbine offshore, as modelled by BVG [2012] for the UK Crown Estate study Offshore Wind Cost Reduction Pathways (OWCRP). The left column shows the split of the O&M cost in its main components for an absolute figure of 74 GBP (85.3 EUR)/kW/yr, which in variable terms equals 32 EUR/kWh at a 40% capacity factor and 95% availability. Downtime breakdown is shown in the right column and it is based on an estimated achievable average of 300 hours per year [BVG, 2012], equivalent to a 96.6% technical availability<sup>35</sup>.

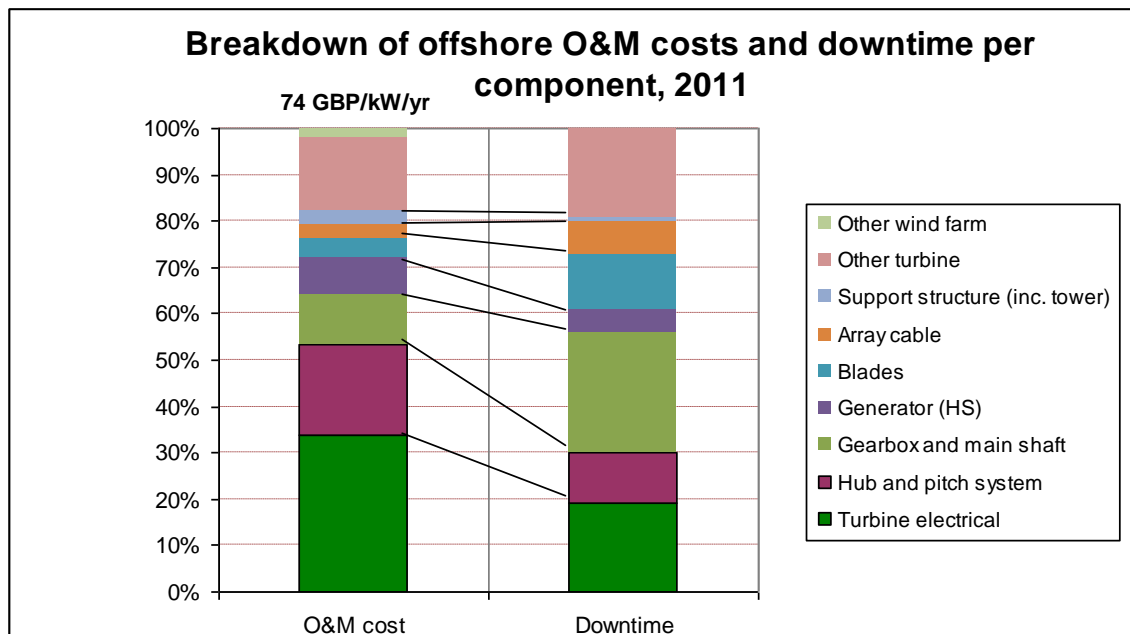

Figure 17: Cost of maintenance offshore, breakdown of the two key indicators: O&M costs and downtime. Source BVG Associates [2012]

The comparison shows a significant difference between downtime and O&M effects for the electrical component of the turbine, which has a higher O&M share (34%) than downtime share (19%). The opposite applies for the gearbox and main shaft which have a more modest 11% O&M share but 26% downtime share.

In order to show the combined economic effect of both O&M costs plus downtime some assumptions are necessary. We have based our assessment on the work of BVG [2012] and expert knowledge as follows:

- Fixed O&M cost for a 4 MW offshore turbine 74 GBP/kW/yr, breakdown of cost as for Figure 17;
- Average downtime 300 hours or 3.4%; this corresponds to 96.6% availability;
- Energy availability lower than turbine availability (turbines are more likely to break down under high loads, which happen during high winds). Therefore the percentage of energy not captured is higher than the downtime percentage and we estimated it at 95%;
- average 2011 exchange rate of 0.868 GBP/EUR results in an O&M cost of **85.26 EUR/kW/yr**;
- theoretical capacity factor 40% or 3 500 hours; energy produced corresponds to 95% energy availability, i.e. 3 330 hours equivalent to 3.33 MWh/kW/yr; downtime results in a loss of 175.2 hours or 0.175 MWh/kW/yr;

<sup>35</sup> The technical availability is lower than 96.5% during the first two years of operation, but 96.5% is considered achievable (even conservative) by industry insiders.

- at a price of 170 EUR per MWh<sup>36</sup> lack of income due to 175.2 hours downtime is **29.8 €/kW/yr**;
- total economic effect is a reduction of **115€/kW/yr**.

These two negative economic impacts can be added according to Figure 17, resulting in the breakdown of total costs per wind farm component AS represented in Figure 18.

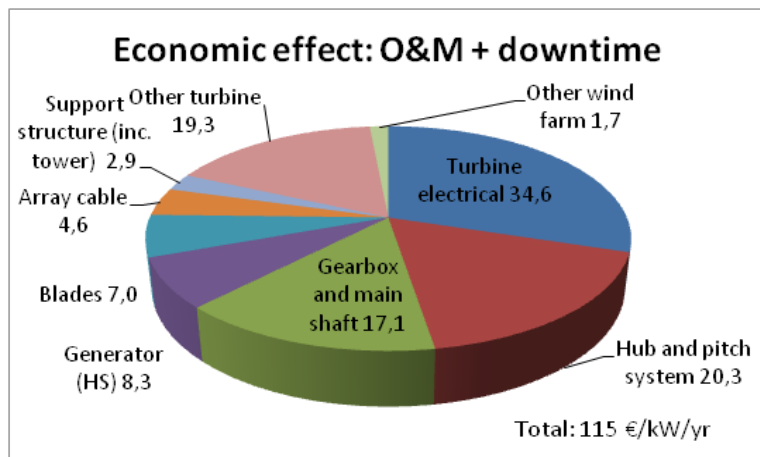

Figure 18: Net economic effect of O&M costs and downtime. JRC calculations based on BVA Associates [2012]

Taking into account other sources as well, a figure for offshore O&M costs is in the range of €25-40/MWh (or €106/kW/yr at a 40 % capacity factor), a range with a European average of €30/MWh [EU, 2011] and towards the upper range for farther offshore installations<sup>37</sup>. The cause of these high costs is mainly the high fixed cost of getting access to the turbines, even when the higher production partly compensates for the difference. Offshore insurance costs, on top of O&M, have

been reported at €5–12/MWh.

#### 4.2.5. Technology learning

There is a learning effect for both improvements to the manufacture of components and for technological improvements which is presented in terms of turbine-cost progress ratio (PR). A PR of 90 %, i.e. a 10% reduction in turbine cost each time that the capacity is doubled, caused cost reductions up to 2003 [NEEDS, 2006; Junginger, 2007]. However, other factors counteracted this effect caused turbine prices to increase, up to 2009, including market unbalance and steep increases in the cost of raw materials.

It is very difficult to estimate the technology learning effect in offshore technology because market and project aspects (e.g. farther offshore wind farms) have had a much higher influence in turbine prices and project costs. The offshore wind sector experienced a period of fierce competition (2000 - 2004) which resulted in neutral PR and, since 2005, a PR above 100% showed the continuous increase of capital costs [GH, 2009] in an effect which can be seen as negating technology learning.

During the last six years, offshore technology R&D has focused on increasing the reliability of turbines which brought about an increase in capital cost and an expected steep reduction in O&M costs and downtime. This will eventually result in a reduction in the cost of energy.

The subject of learning curves in wind energy technology will be addressed in more detail in a forthcoming JRC report.

<sup>36</sup> French auction in 2012 resulted in 202€/MWh. Anholt offshore wind farm will earn 140 €/MWh, but the project did not bear transmission cost; German feed-in-tariffs and UK's income from renewable obligation certificates (ROCs) are consistent with a 170€/MWh level of payment.

<sup>37</sup> Personal communication with leading European turbine manufacturers, developers, and industrial intelligence companies during the course of the summer of 2011, in the context of [EU, 2011]

#### 4.2.6. Integration in the electricity system

The integration of wind energy into the electricity grid may occasionally involve other costs including the reinforcement of grids, and the need for additional balancing power and ancillary services. The first two items have been evaluated in several countries, for example in Denmark at €0.1–5 (for 30 % wind share) and €1–4 (20 % wind share), respectively per MWh of wind electricity [Krohn et al., 2009]. A range of studies in the US shows that costs for wind energy integration of up to 40 % are below €7.5/MWh, and often below €3.8/MWh [Wiser and Bolinger, 2012]. These costs can be reduced through aggregating output of renewable energy sources, creating larger balancing areas, reducing the wholesale market gate-closure times to 4 - 6 hours (as close as possible to delivery time), and more frequent intra-day markets. There is also room for low-cost improvement by optimising the grid operational procedures [Wiser and Bolinger, 2012], such as intra-hour scheduling (e.g. 5-minute scheduling) and better forecasting used by system operators. Integration costs are very difficult to quantify and no single methodology exists; one of the Tasks of IEAWind, Task 25, has analysed this in detail and made recommendations which can be consulted at [http://www.ieawind.org/task\\_25.html](http://www.ieawind.org/task_25.html).

Curtailed is a problem of increasing impact. Curtailment is the forced stopping of wind electricity generation following instructions from grid operators. This happens mostly in two cases, either there is excess (overall) electricity production compared to the existing demand (e.g. on a windy Saturday night), or the local wind generation is larger than what can be absorbed by the transmission lines to the centres of demand.

Curtailed is not regularly quantified in Europe, and it is expected to remain limited, but elsewhere curtailment is having a strong impact: In Texas in 2009, 17 % of the possible wind electricity was curtailed. This figure was reduced to 8 % in 2010 after a new line was built [Wiser and Bolinger, 2012]. In China curtailment is a serious problem with a strong effect to reduce the profit of projects. During 2011, 17% of the expected production was curtailed in China with peaks of 27 % in the Gansu province, 25% in East Inner Mongolia and 23% in West Inner Mongolia, with a loss (in those three regions alone) of 9.7 TWh [CWEA, 2012b].

Geographic diversity significantly reduces the magnitude of extreme changes in the aggregated output of renewable energy sources with high variability such as wind, and hence the cost of managing that variability [Mills and Wise 2010]. For example, the power production could register a hourly variability of 60 % in the case of a single wind farm (350 MW capacity) but only of 20% for aggregated wind farms in Germany and only 10% for Nordel systems. “By aggregating wind power over large regions of Europe, the system can benefit from the complementarities of cyclones and anticyclones over Europe [EWEA 2009c].

#### 4.2.7. Energy produced

The system availability of European onshore wind turbines is above 97 %, among the best of the electricity generation technologies [EWEA, 2009a], although because malfunctions occur most when the wind is blowing strong this 3 % unavailability translates into a higher lost production of maybe 5 %. The typical capacity factors onshore are 1 800 – 2 200 full-load hours equivalent (in which a wind turbine produces at full capacity), and 3 000 – 3 800 offshore, for a European global average of 1 960 hours. Technology progress tends to increase these figures but the best sites onshore have already been taken and new wind farms are built at lower wind speed sites. However, new wind farms built with the new (large rotor, taller tower) turbines maintain and even increase capacity factors.

It is sometimes assumed that energy production from offshore wind farms is more homogeneous than from onshore wind farms. Table 16 shows the energy produced in the Danish offshore wind farms and some located at sea but connected to the shore (called shoreline here). It has to

be noted that year 2010 was, in general, a year with winds below the long-term average in Northern Europe. The table therefore serves as well as an example of year-to-year variability.

Wind farm	Type	MW	Turbine model	No. of WT	MW per WT	Operational	Electricity production (MWh)		Capacity factor	
							2010	2011	2010	2011
Vindeby	O	4,95	B35/450	11	0,45	1991	9 582	8 695	22,1%	20,1%
Tuno Knob	O	5	V39-500	10	0,5	1995	13 435	14 137	30,7%	32,3%
Middelgrunden	O	40	B76/2000	20	2	2001	89 344	88 431	25,5%	25,2%
Horns Rev I	O	160	V80-2.0	80	2	2002	565 844	669 833	40,4%	47,8%
Frederikshavn	O	2,3	N90-2.3	1	2,3	2003	6 763	6 837	33,6%	33,9%
Frederikshavn	O	2,3	B82/2.3 VS	1	2,3	2003	6 447	7 030	32,0%	34,9%
Frederikshavn	S	3	V90-3.0	1	3	2003	8 512	8 930	32,4%	34,0%
Rodsand I (Nysted)	O	165,6	SWT-2.3-93	72	2,3	2003	526 080	600 649	36,3%	41,4%
Ronland	S	8	V80-2.0	4	2	2003	29 170	34 987	41,6%	49,9%
Ronland	S	9,2	SWT-2.3-82	4	2,3	2003	33 985	37 468	42,2%	46,5%
Samso	O	23	SWT-2.3-82	10	2,3	2003	78 426	87 745	38,9%	43,6%
Horns Rev II	O	209,3	SWT-2.3-93	91	2,3	2009	855 516	911 031	46,7%	49,7%
Hvidovre	S	3,6	SWT-3.6-120	1	3,6	2009	10 464	13 353	33,2%	42,3%
Hvidovre	S	3,6	SWT-3.6-120	1	3,6	2009	10 356	11 805	32,8%	37,4%
Sprogo	O	21	V90-3.0	7	3	2009	63 746	66 432	34,7%	36,1%
Rodsand II	O	207	SWT-2.3-93	90	2,3	2010	384 402	833 471	21,2%	46,0%
Hvidovre	S	3,6	SWT-3.6-120	1	3,6	2011	0	3 774	0,0%	12,0%

Table 16: Electricity production from offshore (Type = O) and shoreline (Type = S) wind farms in Denmark, and capacity factors. Source: JRC analysis based on data from ENS.DK

#### 4.2.8. Cost of energy

The fundamentals of the calculation of the levelised cost of energy were described in section 4.1. This subsection exposes recent estimates of the CoE for offshore and onshore projects along with some of their underlying assumptions, and discusses the reasons for the uncertainties.

Indicator / Source	EWI KPI	E&Y	EWI KPI
	onshore	onshore	offshore
Capital, investment cost (€/kW)	1 250	1 240	3 500
O&M costs including insurance(€/kW/yr)	47	28.46	106
Capacity factor (%)	25	24	40
Variable O&M costs in variable terms(see notes) (€/MWh)	21.5	2.53	30.3
Year of currency	2010	2011	2010
Balancing costs (€/MWh)	3	2.53	3
Project lifetime (years)	20	20	25
Real discount rate (%)	5.39	5.88	5.39
Total plant capacity (MW)	40		300
Size of wind turbines (MW)	2.5		5-7
LCoE (€/MWh)	71.8	69.5	106.9
LCoE (€/MWh) by 2020	57.2	55.4	84.8

Table 17: Summary of figures for LCoE and assumptions. Source: see text.

Sources and data details in Table 17:

- EWI KPI: [SETIS, 2011]. It is assumed that O&M are fixed only, the variable O&M figures are for information only and it is the result of making variable the fixed O&M costs according to the capacity factor. Construction time impacts are not included.
- E&Y: Ernst & Young [2012], pages 49, 50, and 53. Costs in GBP translated into EUR at a rate of 0.8688 GBP/EUR. Variable O&M are added to the fixed O&M. A construction time of 2 years has an impact on financial costs and thus on LCoE. Balancing costs as given on p.59. Discount rate 8% was not identified by E&Y whether real or nominal. It was assumed nominal and, along with a 2% inflation rate, resulted in 5.88% real discount rate. The resulting LCoE are the figures from the EWI KPI model, E&Y stated LCoE is 84 EUR/MWh

The analysis of the cost of energy figures by different actors leads to a few conclusions:

- The results depend heavily on the assumptions, and one of the most important ones is the discount rate.
- Underlying costs included tend to be comparable. Most sources include CapEx and OpEx as described e.g. at [SETIS, 2011], financial costs, etc.
- Results depend strongly on the moment when market (and other) prices were taken. Given the behaviour of wind turbine costs, as reflected in Figure 15, its role as trend-setting for the CapEx, and the lead times from order to commissioning, CoE resulting from prices taken in 2010 are very different from 2011 or indeed 2012 prices.

Table 18 shows the projections of costs for different capacity factors and years<sup>38</sup>.

All figures in EUR 2012	2020	2030	2050
Onshore	Capital costs (€/kW)		
Medium capacity factor (23%)	1270	1190	1110
High capacity factor (30%)	1380	1270	1190
Very high capacity factor (38%)	1430	1320	1240
Offshore	Capital costs (€/kW)		
Medium capacity factor (32%)	2600	2380	1950
High capacity factor (40%)	3400	2700	2100
Very high capacity factor (48%)	4200	3300	2700
Onshore	Fixed O&M costs (€/kW)		
Medium capacity factor (23%)	28	24	22
High capacity factor (30%)	30	28	26
Very high capacity factor (38%)	33	30	28
Offshore	Fixed O&M costs (€/kW)		
Medium capacity factor (32%)	72	64	56
High capacity factor (40%)	64	56	47
Very high capacity factor (48%)	89	67	61
	Variable O&M costs (€/MWh)		
Onshore	0.45	0.4	0.3
Offshore	0.8	0.6	0.5

Table 18: Projections for future costs for onshore and offshore wind. Source: JRC

<sup>38</sup> In the absence of project price transparency a relation between increased capacity factor and cost is assumed. This is based on the assumption that increased CF is due to higher wind resources or larger rotor/taller towers. In the former case a more robust wind turbine is necessary (with higher component costs) and in the latter the higher cost of these two elements increase the turbine cost.

#### 4.2.9. Approaches to reducing the cost of energy

Different actors in the wind sector have stated an intention, or expectations, to move into lower cost of energy. As it could be expected by the very different prices onshore and offshore, it is offshore where the objectives are more radical. This is a summary of these statements:

- The UK Department of Energy and Climate Change appointed an industry-led [Offshore Wind Cost Reduction Task Force](#) that unveiled a 30% reduction by 2020 to 100 GBP/MWh.
- The [UK Crown Estate](#) detailed how a reduction to 100 GBP/MWh could be achieved.
- The consultancy [Mott MacDonald](#) [2011] expects as well 100 GBP/MWh.
- The developer [E.ON aims at 40% reduction by 2020](#) in wind farms where the investment decision has been taken by 2015.
- The EPC contractor and offshore developer Hochtief aims at 30% reduction in foundations manufacture and installations by 2022 [JRC, 2012a].
- The consultancy [Deloitte - for the Danish government](#): 25 – 30% by 2020.

Referring to onshore only, Gamesa has stated that [a 30% reduction by 2015 is possible](#).

All those proposals rest on reducing CapEx, OpEx and financial costs, and on increasing annual energy production (AEP). Concretely, actions are proposed in the following areas:

- Legislative: spatial planning, permits, environmental requirements.

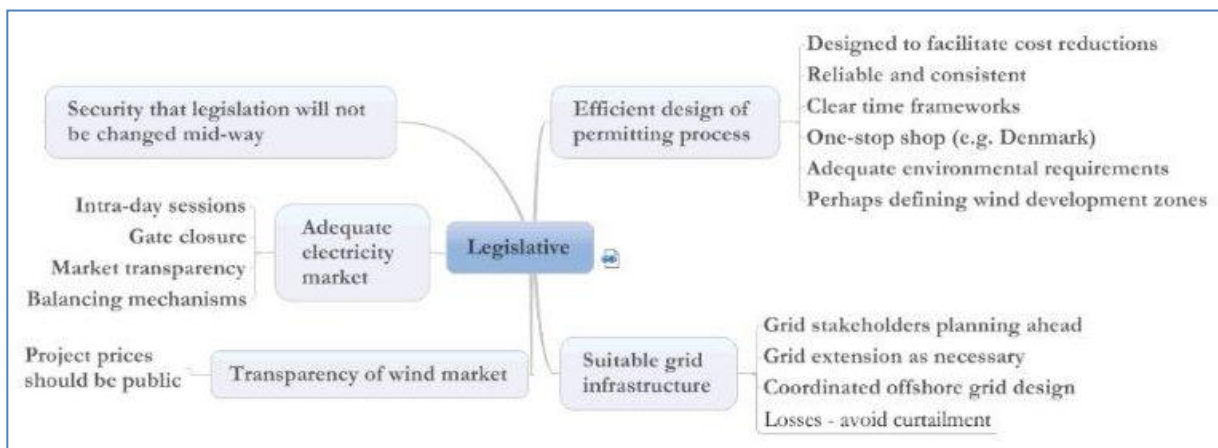

Figure 19: Detail of some of the cost-reduction paths possible through legislative support

- Project development: framework agreements and better coordination with suppliers, large development portfolios (economies of scale), lowering risk premiums, better knowledge of wind conditions.
- Wind farm design: design of elements for lower overall costs, close collaboration with suppliers, reducing the wind farm loss factor, optimum selection of wind turbine.
- Turbine design: larger turbines, series manufacture, automation, design for manufacture.
- Component design: larger blades, drive train, generator, etc. Advanced materials and new designs, obtaining synergies.
- Optimisation of transport, installation and grid connection.
- Reduction of operational losses and downtime.



Figure 19 details some of the legislative aspects within the remit of various authorities and which could help in reducing the cost of electricity from wind.

#### 4.2.10. Conclusion on costs

The expected capital investment trend is for onshore capital costs to reduce further due to non-technological factors such as the increasing sourcing of components from Chinese lower-cost suppliers and entry into the market of Chinese turbine makers. Technology factors such as the increasing size of turbine blades and a move towards PMG will also play a significant role but not so much for reducing CapEx but for reducing OpEx and increasing energy generation. Technology will continue to progress but, as wind turbines are viewed as some kind of commodity, it is likely that non-technological factors will have a stronger influence in the onshore turbine price.

Offshore wind is expected to maintain high costs (yet slightly decreasing) until 2015 and it has more room for factors including technology improvements (e.g. to reduce foundation and installation costs), learning-by-doing, improved supply chain and more competition which could lead to a reduction of 28 % by 2020 [MML, 2011].

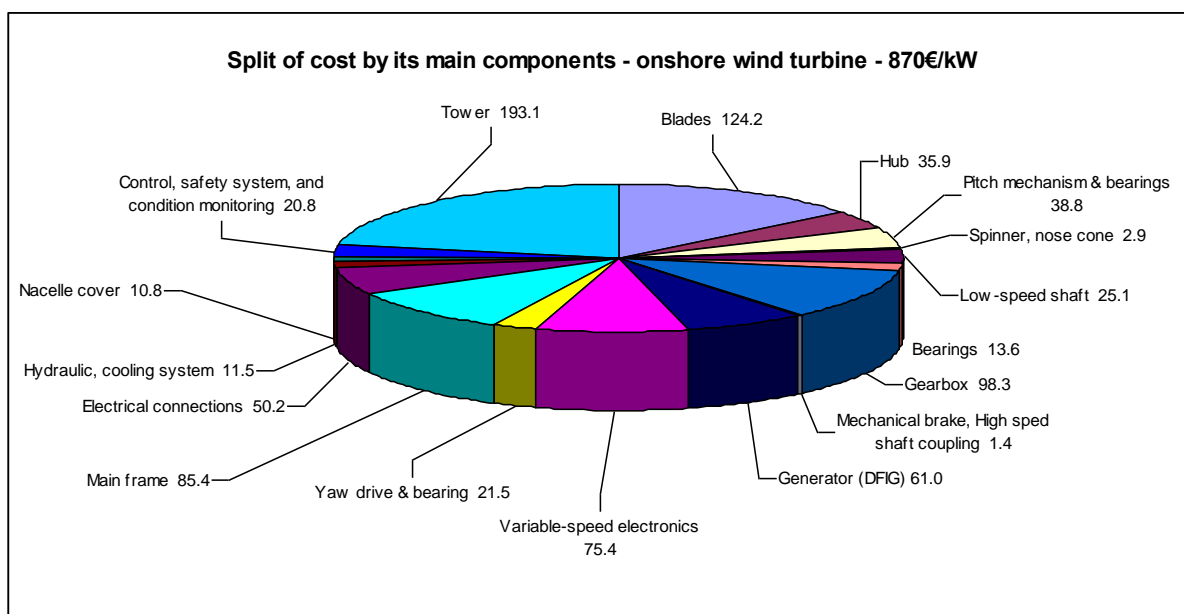

Figure 20: Breakdown of costs by component for an onshore wind turbine. Source: [Wiser and Bolinger, 2012]

Figure 20 shows the cost breakdown for onshore wind turbines based on data from the National Renewable Energy Laboratory (US) for a 1.5 MW model wind turbine. These data are consistent with other sources, as shown in Table 19.

System or subsystem/Source	Onshore (NREL 2012)	Offshore (D-W 2010)	Onshore (EWEA 2007, 100m HH)	Onshore (2006 O'Herlihy, type A)
Rotor hub	4.1%	5.0%	1.4%	3.0%
Blades	14.3%	20.0%	22.2%	20.6%
Pitch control	4.5%		2.7%	7.5%
Spinner, nose cone	0.3%			
Hub bearings	1.6%		1.2%	
Main shaft	2.9%		1.9%	3.8%
Gearbox	11.3%	15.0%	12.9%	11.7%
Generator	7.0%	4.0%	3.4%	8.7%
Controller	2.4%	10.0%		8.2%
Power electronics	8.7%		5.0%	
Nacelle cover	1.2%	2.0%	1.4%	4.0%
Yaw system	2.5%		1.3%	8.6%
Main frame	9.8%		2.8%	
Transformer		4.0%	3.6%	
Electrical connections	5.8%			
Tower	22.2%	25.0%	26.3%	14.7%
Other	2%	15.0%	3.3%	8.9%
Total	100%	100%	89%	100%
Turbine share of project costs	56.2%	44%		57.2%

Table 19: Breakdown of wind turbine costs as percentages, according to different studies. Sources: O'Herlihy [2006], EWEA [2007], Douglass-Westwood [2010], NREL [2012], and BVG [2012].

### 4.3. Other economic impacts

The whole of the economic impact from wind energy depends on where to draw the boundary of the system under analysis, what to include in the system and what to exclude. Elements to be considered include, in a non-exhaustive way: corporate, local and personal taxes, social security contributions, unemployment benefits saved, CO<sub>2</sub> allowances saved, (quantified) security of supply, reduction of fossil fuel imports.

The total value of new generation capacity installed in 2011 is estimated at €50-52 billion, giving a global average CapEx of around €1 240/kW [BTM, 2012; GWEC, 2012]. This is consistent with data calculated from IEA [2012] which shows an average of €1 242/kW for a total of 33.24 GW installed in 17 countries during 2011.

These benefits do not take into account the increased security of supply, reduction in costs of fuel imports and the oil-GDP effect, nor the cost of purchasing carbon under the European Trading Scheme.

#### 4.3.1. Wind and electricity prices

Wind electricity is generally sold in wholesale markets in a way that reduces overall costs for consumers. Demand/supply auctions in wholesale markets result in a final price per period<sup>39</sup> called marginal price, which is the price asked by the most expensive supplier whose electricity offer was accepted, or “matched”. Thereafter all electricity negotiated during the period receives

<sup>39</sup> This period can be one hour, half hour or a quarter hour.

the period marginal price. The detail varies with the specific market but zero-fuel-cost technologies, such as wind, displace fuel-dependent technologies which have a high marginal price and therefore reduce the price paid to all electricity traded, and not just to wind power. Marginal prices are mostly set by fossil fuel or hydropower technologies, the former due to their fuel costs and the latter due to market opportunity.

In particular periods of high fossil fuel prices, the reduction in overall price more than compensates for any subsidy that wind might receive. Calculations in Denmark quantified the related savings, over the period 2004 - 2007, at an average of €3.3/MWh of traded electricity [Krohn et al., 2009].

#### 4.3.2. Feed-in-tariffs

EU legislation on renewable electricity requires that dispatch priority is given to renewable electricity insofar as the operation of the national electricity system permits [EU, 2001]. The electricity produced by wind turbines can be supported by Member States in order to achieve their national targets, and this support has most often taken the form of a feed-in-tariff or feed-in-premium [Ragwitz et al., 2012].

Table 20 gives an indication of the feed-in tariff level in different MS. As in all cases specific conditions apply, any analysis should consult the source of the data, namely the EU project RES-Legal ([www.res-legal.eu](http://www.res-legal.eu)). For example, one of these specific conditions is the duration of the tariff level, another is whether the developer is to pay for any necessary grid extension.

Country	Feed-in tariff amount for wind energy
AT	95 €/MWh (2012), 94.5 €/MWh (2013)
BG	104.43, 132.71 or 148.71 BGN/MWh (about 53, 68, 76 €/MWh)
HR	0.71 HRK/kWh (approx. 94 €/MWh) with an additional 15% possible
CZ	CZK 2.23 – 3.63 per kWh (approx. 90 – 140 €/MWh)
FR	Onshore: 82 €/MWh, offshore: 130 €/MWh (however, see above for auctioned fare)
DE	Onshore: 48.7 – 89.3 €/MWh, repowering bonus 5 €/MWh, plant service bonus of 4.8 €/MWh; offshore: 35 – 190 €/MWh
GR	Between 87.85 and 99.45 €/MWh, additional 20% possible.
HU	3-period tariff: HUF/kWh 12.53 – 13.66 (valley), 13.66 – 30.71 (middle), 21.34 – 34.31 (peak). In €/MWh: 44 – 48 (valley), 48 – 108 (middle), 73 – 120 (peak)
IE	66 €/MWh above 5 MW, 68€/MWh below.
LT	LTL 0.28 per kWh (approx. 80 €/MWh)
LU	82.7 €/MWh
PT	Approximately 74-75 €/MWh
SK	79.29 €/MWh
SI	95.38 €/MWh
ES	81.27 €/kWh
CH	215 CHF/MWh (179 €/MWh) for 5 years, then 135 CHF/MWh (112 €/MWh)
TR	Approx. 56 €/MWh plus a local-content bonus of approx. 5-29 €/MWh
UK	49 GBP/MWh

Table 20: Summary of feed-in tariffs paid in different European countries for wind energy (onshore unless indicated). Source: RES-legal.

An outstanding feature of all feed-in tariff systems is the desire of the legislator not to incur excessive costs for the tax- or ratepayer. Whether this aim has been achieved or not, the perception of politicians and experts was often of failure, but rarely was there enough solid evidence to definitely state whether this aim was achieved. Two elements cause this situation:

- wind projects present high cost variability, and
- there is not enough reliable detailed public data on wind project costs.

Box 4 highlights the importance of reliable data.

Low feed-in tariff levels have failed to stimulate the deployment of wind farms, and high feed-in tariffs have created a glut. However, in some cases high feed-in tariffs were necessary to overcome administrative barriers which raised the cost of deployment, this seems to be the case in Japan where since the 1<sup>st</sup> July 2012, a tariff of 23.1 JPY/kWh (223 €/MWh) is available for 20 years for turbines above 20 kW [METI, 2012].

The impact of the economic crisis in the form of austerity measures aiming at restoring balanced budgets in the MS has caused the reduction of RES support schemes. In some cases, this reduction was meant to adapt the level of remuneration to the diminishing capital costs, most obvious in the case of solar photovoltaic, but also applicable to wind power, so as not to overcompensate project owners. However, some MS have cut back support schemes with retroactive effect (e.g. Spain) which damages investment confidence and that will probably seriously affect the future of the industry and wind generation deployment. Furthermore, the perception that RES are expensive often triggers a great debate in the media when the cost of supporting RES is transferred to the final user but the benefit of it is not perceived.

### 4.3.3. Employment impacts

The wind energy industry employed in Europe around 250 000 persons in 2011 [EurObserv'Er 2012], a 6 % increase from 2010. The industry expects this figures to increase up to 520 000 in 2020 and 794 000 in 2030 (EWEA 2012b)<sup>40</sup>. A spectacular increase is foreseen for offshore wind and in particular for the UK. Cambridge Econometrics for Renewable UK gives three scenarios for employment growth in the offshore sector by 2020: 31 GW installed would create 42 400 direct full time employees (FTEs) and 25 300 indirect FTEs; 23 GW would create 29 700 direct FTEs and 17 500 indirect FTEs; and finally, 13 GW would create 1 800 direct FTEs and 6 400 indirect FTEs<sup>41</sup> [Renewable UK, 2011].

#### Box 4: the impact of data shortcomings.

The importance of public, reliable data is shown by the following example. A sample of capital cost for eight medium-size wind farms commissioned during 2011 in France shows a variation between 1 279 and 1 715 €/kW, in its extreme a 35% variation in project CapEx under the same legislative framework, receiving the same feed-in tariff and in seemingly similar project conditions. This variation of costs suggests that the internal rate of return, as related to the difference from income from the same feed-in tariff and very different level of costs, is very different in these projects.

The detailed analysis of project costs would allow a market-driven adjustment of feed-in tariffs if they are flexible enough, and therefore the minimisation of public expenditure for achieving the agreed renewable energy targets.

The transparency introduced by the publication of detailed project cost breakdown would play a “shaming” role in exposing instances of excessively high prices, and would stimulate competition and eventually lower prices. There is a final argument in favour of public exposure of project costs: accountability. Any project receiving public income – such as feed-in tariffs- should make their data public.

<sup>40</sup> <http://www.ewea.org/policy-issues/economic-benefits/>

<sup>41</sup> <http://myecosolutions.org.uk/windenergy>

However, projections of growth in wind-related employment should be re-interpreted in the context of the ongoing process of delocalisation. Delocalisation causes a reduction of the production capacity in Europe with important consequences on wind employment. New wind markets do not necessarily involve employment growth in Europe as some of these markets (e.g. Ontario in Canada, South Africa) impose local content which aims to create local jobs. In addition, new markets without local content requirements, but away from Europe, will be supplied by European manufacturers from their factories nearer to those markets.

For example, due to insufficient demand in European markets Vestas closed European facilities with significant layoffs in Denmark and the UK (1 567 layoffs in 2009 and 3 000 in 2010). The number of employees outside Europe and Africa rose to 8 127 employees, mostly in USA and China. A further analysis shows that from 2005 to 2010, Vestas R&D and total staff increased in Asia by an annual average of 6.1%. However, sales decreased in the region by a yearly average of 2.45%<sup>42</sup> over the period. The reduction in European R&D personnel (and total staff) reached an annual average of 8.18% for R&D personnel, and a yearly average decrease of 4.7% for European total employment during those years. Meanwhile, the sales continue to increase by a yearly average of 3.6%<sup>42</sup> in Europe. Therefore, the evolution of the revenue distribution is not following the evolution of investments/staff.

Gamesa instead displays a localisation strategy that follows the intensity of sales. From 2006 to 2010 the spatial distribution of its revenues is following investments: the decrease in European capacities is following the decrease in European sales. However, employment in Europe decreased at a slower pace than revenues. The reduction in European total employment reached 2.6 % annually, while annual sales decreased by 6.7%<sup>42</sup> over the period. Sales in Asia increased from 8% to 24% of the total. For example, sales in China increased annually by 1.9% over the period, while the employment capacity increased by an average of 1.6%. The deployment of facilities follows the one of sales and therefore Gamesa follows an intensified globalisation process. Further analysis on international competitors should indicate the extent to which adjustment of production capacities was dictated by the necessity to meet market demand.

There are other sources that suggest that the projected number of employees required are too high. Balmer [2012] suggests that with more capable vessels, installing large numbers of turbines per field and with a better ability to move in wave heights so that the operating season increases from 20-30% to, say 50- 75% of the year, it can be expected that the number of crews required would be far less than would be required to install the same number of turbines, so that the total number of people is lower than currently required per unit installed. Having less downtime per year, and better vessels to work on, will enhance working conditions, and hence attractiveness of conditions improves, so the issue would actually be less serious than it at first seems to be.

The ship will only have a very small crew, however in addition to the "crew", there will be specialist riggers, wind turbine installers and service staff. These tend to come from the technology company and as such are incredibly mobile and almost certainly will come from the country of manufacture of the turbine, rather than the place the turbines are erected in [Balmer, 2012].

---

<sup>42</sup> Linear estimation

## 5. REFERENCES:

4COffshore database of offshore wind farms. Available at [www.4coffshore.com](http://www.4coffshore.com), accessed August 2012.

Addie, Gordon, 2012: *South Africa's renewable energy plans face further delays*. Green Business Guide, 11.10.12. Available at [www.greenbusinessguide.co.za/south-africas-renewable-energy-plans-face-further-delays](http://www.greenbusinessguide.co.za/south-africas-renewable-energy-plans-face-further-delays), accessed on 30.10.12.

Balmer, N., 2012: email exchange and posts at the Claverton Energy Research Group forum of energy specialists, [www.claverton-energy.com](http://www.claverton-energy.com). Edited by the main author.

Bannigan, C.: *Superconducting generator: one small step?* 1st February 2011, Power Engineering International. Accessed on 15.12.12 at <http://www.powergenworldwide.com/index/display/articledisplay/8435051715/articles/power-engineering-international/volume-18/issue-2/features/superconducting-generator.html>

Banja, M; Monforti-Ferrario, F; Scarlat, N, forthcoming: *Review of Technical Assessment of National Renewable Energy Action Plans*. JRC Scientific and Policy reports.

Bloomberg New Energy Finance (BNEF), 2012a. *Wind turbine price index*, issue VII, 24.07.12, and previous issues.

Bloomberg New Energy Finance (BNEF), 2012b. *Q3 2012 Wind market outlook*, 14.08.12.

BTM Consult, 2010: *World Market Update 2009*, March 2010.

BTM Consult, 2011. *World Market Update 2010*, March 2011.

BTM Consult, 2012: *World Market Update 2011*, March 2012.

BVG Associates, 2012: *Offshore wind cost reduction pathways, Technology work stream*. June 2012.

BWE (Bundestverband WindEnergie), German wind industry association. Repowering brief, [www.wind-energie.de/node/1496](http://www.wind-energie.de/node/1496) accessed 31.10.12.

Carbon Trust of the UK (CT), 2011: presentation on the foundations competition which left four innovative designs for the next phase of testing: MBD's suction bucket monopile; Keystone's twisted jacket; Gifford/BMT/Freyssinet gravity structure; and SPT Offshore/Wood Group's tribucket design.

Chen, Gang, Vice General Manager Dongfang Electric New Energy Equipment (Hangzhou) Co., Ltd.). Personal communication at Husum Wind Energy Fair, September 2012.

Chen J (2011) Renewable Energy Supply Chains International Economic Development Council

Chinese Wind Energy Association, 2012a: *Installed wind power capacity in China: 2011 Statistics* (in Chinese). Available at [cwea.org.cn](http://cwea.org.cn)

Chinese Wind Energy Association, 2012b: *2011 wind curtailment in China: preliminary statistics* (in Chinese). Available at [cwea.org.cn](http://cwea.org.cn)

Cohen, 2012. South Africa Seeks New Bids for 3,200 Megawatts of Green Energy. Renewable Energy World, 29.10.12. Available at [www.renewableenergyworld.com/rea/news/article/2012/10/south-africa-seeks-new-bids-for-3200-megawatts-of-green-energy](http://www.renewableenergyworld.com/rea/news/article/2012/10/south-africa-seeks-new-bids-for-3200-megawatts-of-green-energy), consulted 30.10.12.

Deloitte (2011): *Analysis on the furthering of competition in relation to the establishment of large offshore wind farms in Denmark*. Report for the Danish Ministry of Climate and Energy, 2011. Available at [www.ens.dk/en-US/supply/Renewable-energy/WindPower/offshore-Wind-Power/Future-offshore-wind-parks/Documents/Deloitte%20-Summary.pdf](http://www.ens.dk/en-US/supply/Renewable-energy/WindPower/offshore-Wind-Power/Future-offshore-wind-parks/Documents/Deloitte%20-Summary.pdf), accessed 15.11.12.

- Dong Energy, 2012. Personal and email communication, September and October 2012.
- Donoso, José, 2012: *Las subastas en Brasil, ¿un ejemplo a exportar?* Energías Renovables, 26.10.12. Available at [www.energias-renovables.com/articulo/las-subastas-en-brasil--un-ejemplo-20121026](http://www.energias-renovables.com/articulo/las-subastas-en-brasil--un-ejemplo-20121026), consulted 30.10.12
- Douglass-Westwood, 2010: *Offshore Wind Assessment for Norway*, final report for the Research Council of Norway, 24<sup>th</sup> March 2010.
- Dziopa, Dariusz, Estimator. Energomontaz Polnoc Gdynia (a foundation manufacturer), personal communication September 2012.
- EDF Renewable Energy, 2012: press release “EDF Renewable Services Signs Operations and Maintenance Agreement for 222.4 Megawatts with Detroit E”. Available at [www.edf-re.com/about/press/edf\\_renewable\\_services\\_signs\\_operations\\_and\\_maintenance\\_agreement\\_for\\_222.4](http://www.edf-re.com/about/press/edf_renewable_services_signs_operations_and_maintenance_agreement_for_222.4), accessed 15.11.12.
- Elsam Engineering, 2004: Life Cycle Assessment of offshore and onshore sited wind farms. Available at [http://www.apere.org/manager/docnum/doc/doc1252\\_LCA\\_V80\\_2004\\_uk\[1\].fiche%2042.pdf](http://www.apere.org/manager/docnum/doc/doc1252_LCA_V80_2004_uk[1].fiche%2042.pdf), accessed 15.11.12. The wind turbine is the Vestas V80-2.0MW with 78m tower
- Ernst & Young, 2012: *Analysis of the value creation potential of wind energy policies. A comparative study of the macro-economic benefits of wind and CCGT power generation*. May 2012.
- EurObserv'ER 2012 Observatoire des Energies Renouvelables, Geographic Information System, available at [www.energies-renouvelables.org/barometre.asp](http://www.energies-renouvelables.org/barometre.asp) accessed, 14.11.12
- European Commission (2007). Communication from the Commission to the Council, the European Parliament, the European Economic and Social Committee and the Committee of the Regions - A European strategic energy technology plan (SET-plan)-Towards a low carbon future, COM/2007/723. Available from [http://ec.europa.eu/energy/technology/set\\_plan/set\\_plan\\_en.htm](http://ec.europa.eu/energy/technology/set_plan/set_plan_en.htm)
- European Commission (2011): COM(2011) 112 final: *A roadmap for moving to a competitive low carbon economy in 2050*.
- European Commission (2012): European Energy Programme for Recovery. Information available at [ec.europa.eu/energy/eepr/index\\_en.htm](http://ec.europa.eu/energy/eepr/index_en.htm), accessed 15.11.12.
- European Union (EU), 2001. Directive 2001/77/EC of the European Parliament and of the Council of 27 September 2001 on the promotion of electricity produced from renewable energy sources in the internal electricity market.
- European Union (EU), 2011. On-going work of the Team of the European Wind Industrial Initiative, made up by representatives of the Member States and the European Commission.
- European Wind Energy Association (EWEA), 2007. *WindDirections* January/February 2007, quoted in EWEA [2009b].
- European Wind Energy Association (EWEA) 2009a: *Wind Energy-the Facts. Part I - Technology*. Available at [www.wind-energy-the-facts.org](http://www.wind-energy-the-facts.org), accessed 2.11.12
- European Wind Energy Association (EWEA), 2009b. *The economics of wind*. Available at [www.ewea.org](http://www.ewea.org), accessed 2.11.12
- European Wind Energy Association (EWEA), 2009c. *Grid integration*. Available at [www.ewea.org](http://www.ewea.org), accessed 2.11.12
- European Wind Energy Association (EWEA), 2012a: *Wind in power: 2011 European statistics*. Available at [www.ewea.org](http://www.ewea.org).

- European Wind Energy Association (EWEA), 2012b. *Green Growth*. Available at [www.ewea.org](http://www.ewea.org), accessed 14.11.12
- European Wind Technology Platform (TPWind), 2010. *Wind European Industrial Initiative Team, 2010-2012 Implementation Plan*, May 2010. Available at [setis.ec.europa.eu/implementation/eii/implementation-plans/Wind\\_EII\\_Implementation\\_Plan\\_final.pdf/view](http://setis.ec.europa.eu/implementation/eii/implementation-plans/Wind_EII_Implementation_Plan_final.pdf/view)
- Gifford (2007): *Concrete towers for onshore and offshore wind farms: conceptual design studies*. Conceptual design study for The Concrete Centre, ISBN 1-904818-48-X. Available at [www.bwea.com/pdf/concrete%20towers.pdf](http://www.bwea.com/pdf/concrete%20towers.pdf)
- Guillet, J., 2012: email exchange and posts at the Claverton Energy Research Group forum of energy specialists, [www.claverton-energy.com](http://www.claverton-energy.com). Edited by the main author.
- GL-GH (GL Garrad Hassan), 2012: *Assessment of the estimated costs of wind energy in British Columbia*. For the Canadian Wind Energy Association.
- Guezuraga, B., Zauner, R., and Pölz, W: *Life cycle assessment of two different 2 MW class wind turbines*. *Renewable Energy* 37 (2012) 37-44
- GWEC (Global Wind Energy Council), 2012: *Global Wind Report — Annual market update 2011*, April 2012; downloaded 2<sup>nd</sup> November 2012 from [www.gwec.net](http://www.gwec.net)
- Hatch, G. P.: *Critical Rare Earths. Global supply & demand projections and the leading contenders for new sources of supply*. Available at [www.criticalrareearthreport.com/downloads/cre-0811.pdf](http://www.criticalrareearthreport.com/downloads/cre-0811.pdf), accessed 15.11.12
- IEAWind, 2012: *2011 Annual Report*. International Energy Agency Wind Implementing Agreement. Available at [www.icawind.org](http://www.icawind.org)
- Jacobsson, S., Bergek, A, 2004. *Transforming the Energy Sector: The evolution of technological systems in renewable energy technology*, *Industrial and Corporate Change*, 13(5), 815-849
- Jamieson, Peter, 2011: *Innovation in wind turbine design*, first edition. John Wiley & Sons, Ltd. 2011. ISBN 978-0-470-69981-2.
- Joint Research Centre (JRC) of the European Commission, 2009a: *R&D Investment in the Priority Technologies of the European Strategic Energy Technology Plan*, JRC Reference Reports, report EUR 23944 EN.
- Joint Research Centre (JRC) of the European Commission, 2011a: *2011 Technology Map of the European Strategic Energy Technology Plan (SET-Plan), Technology Descriptions*. JRC Scientific and Technical Report, ISBN 978-92-79-21630-5. Available at [setis.ec.europa.eu/about-setis/technology-map](http://setis.ec.europa.eu/about-setis/technology-map)
- Joint Research Centre (JRC) of the European Commission, 2011b: *Critical Metals in Strategic Energy Technologies. Assessing Rare Metals as Supply-Chain Bottlenecks in Low-Carbon Energy Technologies*. JRC Scientific and Technical Report, ISBN 978-92-79-20698-6. Available at [setis.ec.europa.eu/newsroom-items-folder/jrc-report-on-criticalmetals-in-strategic-energy-technologies](http://setis.ec.europa.eu/newsroom-items-folder/jrc-report-on-criticalmetals-in-strategic-energy-technologies)
- Joint Research Centre (JRC) of the European Commission, 2011c: *Monitoring industrial research: The 2011 EU Industrial R&D Investment Scoreboard*, JRC Reference Reports, JRC 67197
- Joint Research Centre (JRC) of the European Commission, 2012a: data from JRC databases and information collected from industry directly by the JRC, e.g. at Husum Wind Energy fair 2012.
- Joint Research Centre (JRC) of the European Commission 2012b: *R&D Investment in the Priority Technologies of the European Strategic Energy Technology Plan*, JRC Reference Reports



Joint Research Centre (JRC) of the European Commission, 2012c: *Scientific Assessment in support of the Materials Roadmap enabling Low Carbon Energy Technologies: Wind Energy*. L.G.J. Janssen (rapporteur), R. Lacal Arántegui, P. Brøndsted, P. Gimondo, A. Klimpel, B.B. Johansen, P. Thibaux, 2012.

Krohn, S., Morthorst, P-E., Awerbuch, S., 2009: *The Economics of Wind Energy*. EWEA 2009.

Llorente Iglesias R., Lacal Arantegui, R., Aguado Alonso, R., 2011. *Power electronics evolution in wind turbines—A market-based analysis*. *Renew Sustain Energy Rev* (2011), doi:10.1016/j.rser.2011.07.056.

Mann, J., 2012: “How an advanced wind atlas can help reduce CoE”. Email of 28.08.12 within the context of EU [2012]. Mr Jakob Mann is wind energy professor at Technical University of Denmark.

Ministry of Economy, Trade and Industry (METI) of Japan: *Settlement of the Details of the Feed-in Tariff Scheme for Renewable Energy, Including Purchase Price and Surcharge Rates*. Press release 18.06.12, available at [www.meti.go.jp/english/press/2012/0618\\_01.html](http://www.meti.go.jp/english/press/2012/0618_01.html), accessed 8.11.12.

Mills, A., Wise, R., 2010. Implications of Wide-Area Geographic Diversity for Short-Term Variability of Solar Power, Lawrence Berkeley National Laboratory, [escholarship.org/uc/item/9mz3w055](http://escholarship.org/uc/item/9mz3w055)

Mott MacDonald (MML), 2011. *Costs of low-carbon generation technologies*. Report for the UK’s Committee on Climate Change, May 2011.

National Renewable Energy Laboratory (NREL), 2012: *2010 Cost of Wind Energy Review*. S. Tegen, M. Hand, B. Maples, E. Lantz, P. Schwabe, and A. Smith.

O’Herlihy & Co. Ltd, 2006: *Windfarm Construction: Economic Impact Appraisal. A Final Report to Scottish Enterprise*. March 2006.

Oakdene Hollins for Department for Transport, UK, 2010. *Lanthanide Resources and Alternatives*.

Pavitt, K., 1984. *Sectoral patterns of technical change: towards a taxonomy and a theory*. *Research Policy* 13: 343–373. doi:10.1016/0048-7333(84)90018-0.

Porter, M.E., 1980 *Competitive Strategy: Techniques for analyzing industries and competitors* New York: The Free Press.

Ragwitz, M., Winkler, J., Klessmann, C., Gephart, M., and Resch, G.: *Recent developments of feed-in systems in the EU – A research paper for the International Feed-In Cooperation*. January 2012.

RenewableUK, 2011: Working for a greater Britain , Volume 2. Available at [www.renewableuk.com](http://www.renewableuk.com) .

RenewableUK press release 30.10.12: *Wind industry hails “new era of development” as deployment and investment surge*. Available at [www.renewableuk.com/en/news/press-releases.cfm/2012-10-30-wind-industry-hails-new-era-of-development-as-deployment-and-investment-surge?](http://www.renewableuk.com/en/news/press-releases.cfm/2012-10-30-wind-industry-hails-new-era-of-development-as-deployment-and-investment-surge?) Accessed 31.10.12.

Szabó, M., Jäger-Waldau, A., Monforti-Ferrario, F., Scarlat, N., Bloem, H., Quicheron, M., Huld, T., Ossenbrink, H., 2011: *Technical Assessment of the Renewable Energy Action Plans*, JRC reference report EUR 24926 EN

SETIS (Information System of the European Strategic Energy Technology Plan (SET-Plan)), 2011: *Key Performance Indicators for the Wind European Industrial Initiative*. Available at [setis.ec.europa.eu/implementation/eii/eii-key-performance-indicators/KPIs\\_Wind/view](http://setis.ec.europa.eu/implementation/eii/eii-key-performance-indicators/KPIs_Wind/view), accessed 10.11.12.

Tindal, A.: *Financing wind farms and the impacts of P90 and P50 yields*. Presentation at EWEA Wind Resource Assessment Workshop, 11.05.11. Available at [old.ewea.org/fileadmin/ewea\\_documents/documents/events/2011\\_technology\\_workshop/presentations/Session\\_5.1\\_Andrew\\_Tindal.pdf](http://old.ewea.org/fileadmin/ewea_documents/documents/events/2011_technology_workshop/presentations/Session_5.1_Andrew_Tindal.pdf). Accessed 15.11.12.

TPWind (wind technology platform), 2011: A new EU Wind Energy Atlas: Proposal for an ERANET+ project. Unpublished.

Vestas, 2012: *Rare Earth Elements from a Life Cycle Assessments perspective*. Available at [www.vestas.com/en/about-vestas/sustainability/sustainable-products/life-cycle-assessment/rare-earth-elements.aspx](http://www.vestas.com/en/about-vestas/sustainability/sustainable-products/life-cycle-assessment/rare-earth-elements.aspx), accessed 15.11.12

Wilkinson, M., Harman, K., and Hendriks, B., 2011: *Measuring wind reliability: results of the ReliaWind project*. Presented at the conference EWEA 2011, available at [www.garradhassan.com/assets/downloads/Measuring\\_Wind\\_Turbine\\_Reliability\\_-\\_Results\\_of\\_the\\_Reliawind\\_Project.pdf](http://www.garradhassan.com/assets/downloads/Measuring_Wind_Turbine_Reliability_-_Results_of_the_Reliawind_Project.pdf) accessed 15.11.12.

Wiser, R, and Bolinger, M., 2012: *2011 Wind Technologies Market Report*. Lawrence Berkeley National Laboratory for the US Department of Energy, July 2012.

Zimmermann, T., 2011: *Parameterized tool for site specific LCAs of wind energy converters*. *Int J Life Cycle Assess* DOI 10.1007/s11367-012-0467-y.

European Commission

EUR 25647 – Joint Research Centre – Institute for Energy and Transport

Title: 2012 JRC wind status report

Author(s): Roberto Lacal Arántegui, main author; Teodora Corsatea and Kiti Suomalainen, contributing authors.

Luxembourg: Publications Office of the European Union

2013 – 68 pp. – 21.0 x 29.7 cm

EUR – Scientific and Technical Research series – ISSN 1831-9424 (online), ISSN 1018-5593 (print)

ISBN 978-92-79-27955-3 (pdf)

ISBN 978-92-79-27956-0 (print)

doi:10.2790/72493

As the Commission's in-house science service, the Joint Research Centre's mission is to provide EU policies with independent, evidence-based scientific and technical support throughout the whole policy cycle.

Working in close cooperation with policy Directorates-General, the JRC addresses key societal challenges while stimulating innovation through developing new standards, methods and tools, and sharing and transferring its know-how to the Member States and international community.

Key policy areas include: environment and climate change; energy and transport; agriculture and food security; health and consumer protection; information society and digital agenda; safety and security including nuclear; all supported through a cross-cutting and multi-disciplinary approach.

